

INLINE sensor-fitting with paddle wheel for flow measurement

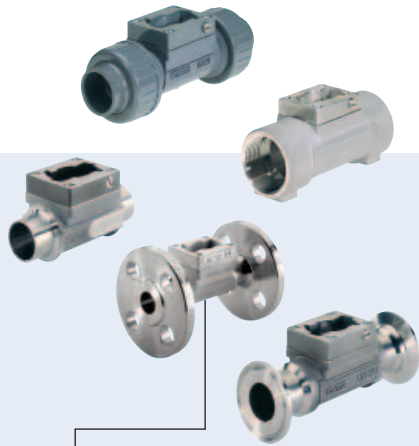

Type S030 can be combined for...



Type 8030
Flowmeter



Type 8032
On/Off flowmeter



Type SE30 Ex
Flowmeter
ATEX version

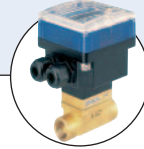

Type 8035
Flowmeter



Type 8036
Flowmeter



Type 8611
Universal-Controller
eControl

- DN06 to DN65
- Closed pipe system, i.e. sensor included in fitting
- Quarter-turn technology
- Transmitter available also with extended functions
 - Indication, Monitoring, Transmitting
 - On/Off control, Batch control

The sensor-fitting S030 has a built-in paddle wheel to measure the flow rate. When liquid flows through the pipe, the paddle wheel is set in rotation producing pulses which frequency is proportional to the flow rate.

The Bürkert special construction, called "IN-LINE Quarter-turn" technology, ensures leakage free operation.

The paddle wheel rotation (permanent magnets included in the wheels) is detected contactless through the sensor-fitting wall. The transmitter can be snapped-on or removed without opening the pipe or interrupting the process.

The Bürkert Quarter-turn technology



General data	
Pipe diameter	DN06 to DN65
Measurement range	from 0.5 to 1200 l/min
Flow velocity	0.3 to 10 m/s (see flow diagram)
Measurement error	Teach-In (via a remote transmitter) ±0.1% of Reading ¹⁾ (at the teach flow rate value) Standard K-factor ±2.5% of Reading ¹⁾
Linearity¹⁾	±0.5% of F.S.*
Repeatability¹⁾	±0.4% of Reading
Process connections	Metal Plastic Internal or external thread, weld ends, Clamp or flange True union, spigot or external thread
Materials	Seal Body Screws Paddle wheel Shaft and bearings FKM or EPDM (depending on version, see ordering chart) Stainless steel (316L -1.4404), brass (CuZn ₃₉ Pb ₂), PVC, PP, PVDF Stainless steel (316L -1.4404) PVDF (PP on request or stainless steel, see data sheet 8030HT) Ceramics (Al ₂ O ₃)
Medium data	
Medium temperature	0 to 50°C (32 to 122°F) for sensor-fitting in PVC 0 to 80°C (32 to 176°F) for sensor-fitting in PP -15 to 100°C (5 to 212°F) for sensor-fitting in stainless steel, brass or PVDF
Medium pressure (max.)	see pressure/temperature chart Metal Plastic PN16 (232.16 PSI) (PN40 (580.4 PSI) on request) PN10 (145.1 PSI)
Fluid properties	clean, neutral or slightly aggressive, solid-free liquids Pollution Viscosity max. 1%, size of particles 0.5 mm max. 300 cSt. max.

* F.S. = Full scale (10 m/s)

¹⁾ Under reference conditions i.e. measuring fluid = water, ambient and water temperature = 20°C, applying the minimum inlet and outlet pipe straights, matched inside pipe dimensions.

Environment	
Ambient temperature (operating and storage)	-15 to 60°C (5 to 122°F) for sensor-fitting in PVC -15 to 80°C (5 to 176°F) for sensor-fitting in PP -15 to 100°C (5 to 212°F) for sensor-fitting in stainless steel, brass or PVDF depending on associated transmitter
Standards, directives and approvals	
Directive - Pressure	Complying with article 3 of §3 from 97/23/CE directive.*
Approval/Certificate on request	3.1 certificate; 2.2 certificate; surface finish certificate; calibration certificate; FDA (with EPDM seal) - stainless steel sensor-fitting only

* For the 97/23/CE pressure directive, the device can only be used under following conditions (dependent on max. pressure, pipe diameter and fluid).

Type of fluid	Conditions
Fluid group 1, §1.3.a	DN ≤ 25 only
Fluid group 2, §1.3.a	DN ≤ 32 or DN > 32 and PN*DN ≤ 1000
Fluid group 1, §1.3.b	PN*DN ≤ 2000
Fluid group 2, §1.3.b	DN ≤ 200

Pressure/temperature diagram

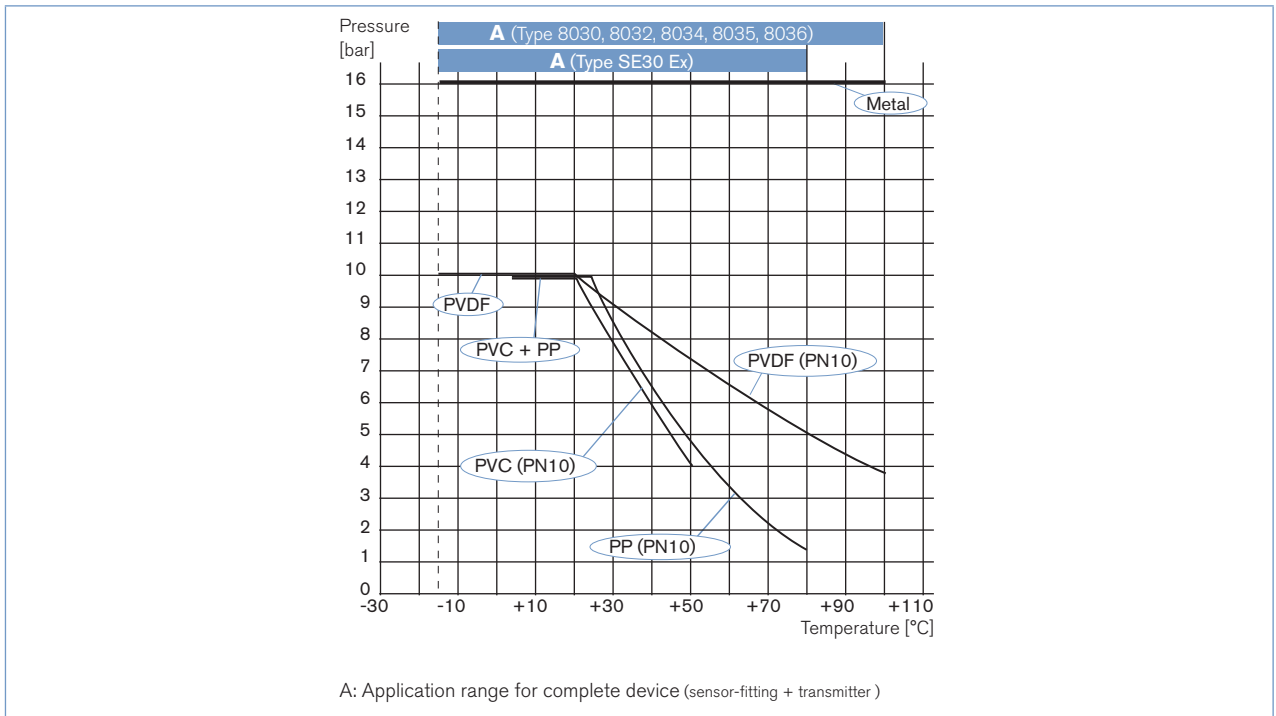

Installation

Minimum straight upstream and downstream distances must be observed. According to the pipe's design, necessary distances can be bigger or use a flow conditioner to obtain the best accuracy. For more information, please refer to EN ISO 5167-1.

EN ISO 5167-1 prescribes the straight inlet and outlet distances that must be complied with when installing sensor-fittings in pipe lines in order to achieve calm flow conditions. The most important layouts that could lead to turbulence in the flow are shown below, together with the associated prescribed minimum inlet and outlet distances. These ensure calm, problem-free measurement conditions at the measurement point.

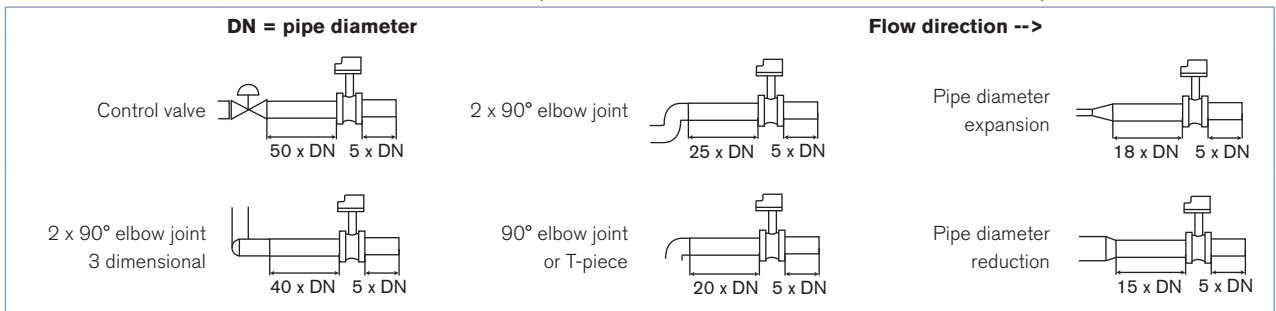

Installation

The device can be installed into either horizontal or vertical pipes.

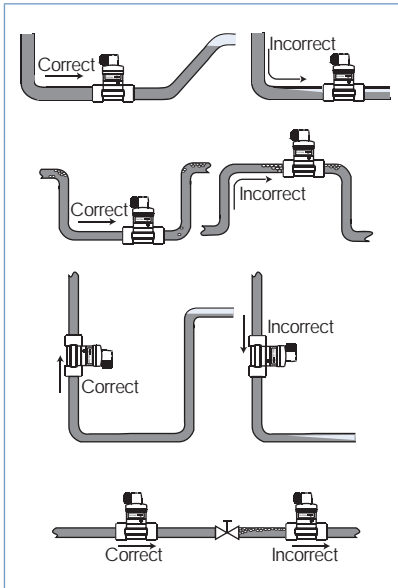

Pressure and temperature ratings must be in accordance to the selected sensor-fitting material.

The suitable pipe size is selected using the diagram Flow/Velocity/DN.

Construction

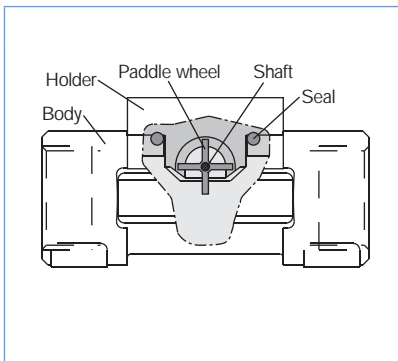
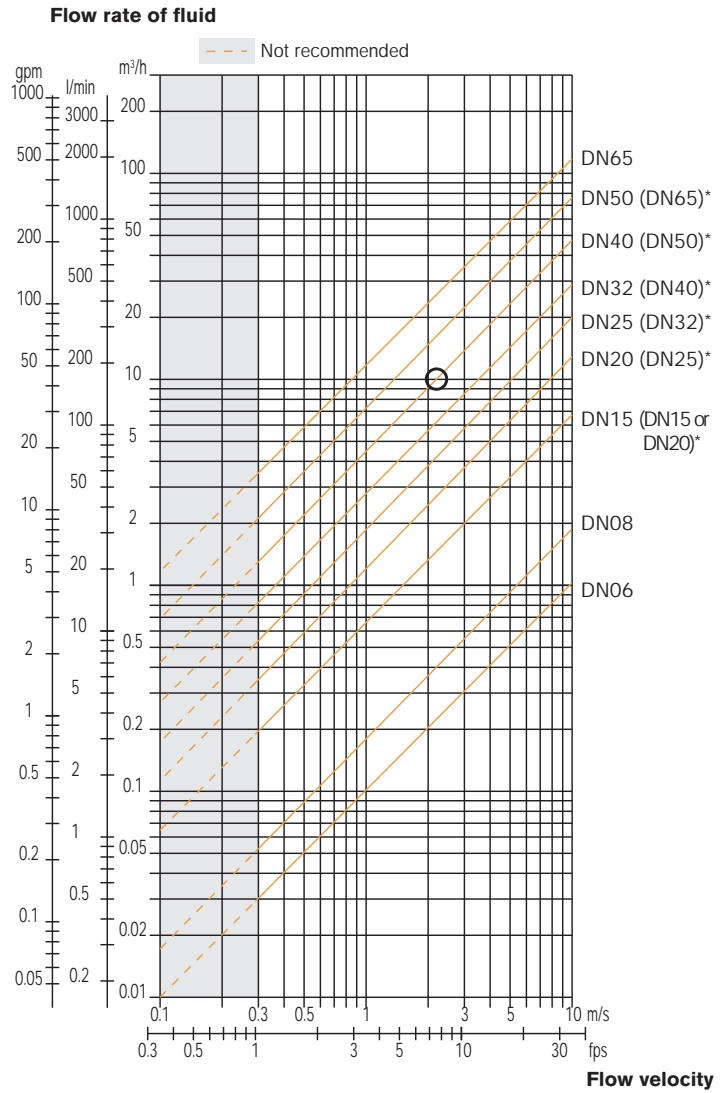

Diagram Flow/Velocity/DN

Example:

- Flow: 10 m³/h
- Ideal flow velocity: 2... 3 m/s

For these specifications, the diagram indicates a pipe size of DN40 [or DN50 for (*) mentioned sensor-fittings]



* for following fittings with:

- external threads acc. to SMS 1145
- weld ends acc. to SMS 3008, BS 4825/ASME BPE or DIN 11850 Series 2
- Clamp acc. to SMS 3017/ISO 2852, BS 4825/ASME BPE or DIN 32676

INLINE sensor-fitting dimensions

Internal thread connection

G, NPT or Rc
 in stainless steel (316L - 1.4404) or
 brass (CuZn39Pb2)

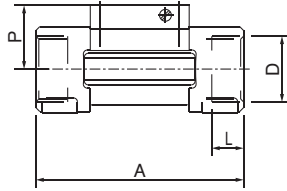

DN	P	A	D	L
[mm]	[mm]	[mm]	[inch]	[mm]
15	34.5	84.0	G 1/2 NPT 1/2 Rc 1/2	16.0 17.0 15.0
20	32.0	94.0	G 3/4 NPT 3/4 Rc 3/4	17.0 18.3 16.3
25	32.2	104.0	G 1 NPT 1 Rc 1	23.5 18.0 18.0
32	35.8	119.0	G 1 1/4 NPT 1 1/4 Rc 1 1/4	23.5 21.0 21.0
40	39.6	129.0	G 1 1/2 NPT 1 1/2 Rc 1 1/2	23.5 20.0 19.0
50	45.7	148.5	G 2 NPT 2 Rc 2	27.5 24.0 24.0

External thread connection

G, NPT or Rc
 in stainless steel (316L - 1.4404),
 brass (CuZn39Pb2),
 PVC (only DN6 and DN8)
 or PVDF (only DN8)

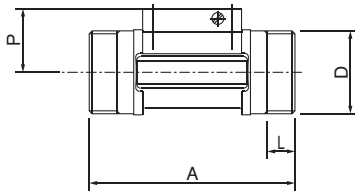

DN	P	A	D	L
[mm]	[mm]	[mm]	[inch]	[mm]
06	29.5	90.0	G 1/2	-
08	29.5	90.0	** 1/2	M 16 x 1.5
15	34.5	84.0	G 3/4	-
20	32.0	94.0	G 1	-
25	32.2	104.0	G 1 1/4	-
32	35.8	119.0	G 1 1/2	-
40	39.6	129.0	-	M 55 x 2
50	45.7	148.5	-	M 64 x 2

** G, NPT, RC according to sensor-fitting version

External thread connection

SMS 1145,
 in stainless steel (316L - 1.4404)

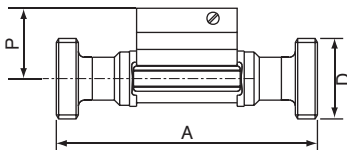

DN	P	A	D
[mm]	[mm]	[mm]	
25	32.0	130	Rd 40 x 1/6"
40	35.8	164	Rd 60 x 1/6"
50	39.6	173	Rd 70 x 1/6"

INLINE sensor-fitting dimensions

Weld end connection

EN ISO 1127/ISO 4200, SMS 3008 or
BS 4825/ASME BPE or DIN 11850 Series 2
in stainless steel (316L - 1.4404)

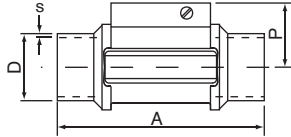

DN	P	A	Standard	D	s
[mm]	[mm]	[mm]		[mm]	[mm]
08	-	-	EN ISO 1127/ISO 4200	-	-
	-	-	SMS 3008	-	-
	-	-	ASME BPE	-	-
	29.5	90.0	DIN 11850 Series 2	13.00	1.50
15	34.5	84.0	EN ISO 1127/ISO 4200	21.30	1.60
	-	-	SMS 3008	-	-
	-	-	ASME BPE	-	-
	34.5	84.0	DIN 11850 Series 2	19.0	1.50
20	32.0	94.0	EN ISO 1127/ISO 4200	26.9	1.60
	-	-	SMS 3008	-	-
	34.5	84.0	ASME BPE	19.05	1.65
	34.5	84.0	DIN 11850 Series 2	23.00	1.50
25	32.2	104.0	EN ISO 1127/ISO 4200	33.70	2.00
	32.0	94.0	SMS 3008	25.00	1.20
	32.0	94.0	BS 4825/ASME BPE	25.40	1.65
	32.0	94.0	DIN 11850 Series 2	29.00	1.50
32	35.8	119.0	EN ISO 1127/ISO 4200	42.40	2.00
	-	-	SMS 3008	-	-
	32.2	104.0	BS 4825/ASME BPE	32.00	1.65
	32.2	104.0	DIN 11850 Series 2	35.00	1.50
40	39.6	129.0	EN ISO 1127/ISO 4200	48.30	2.00
	35.8	119.0	SMS 3008	38.00	1.20
	35.8	119.0	BS 4825/ASME BPE	38.10	1.65
	35.8	119.0	DIN 11850 Series 2	41.00	1.50
50	45.7	148.5	EN ISO 1127/ISO 4200	60.30	2.60
	39.6	128.0	SMS 3008	51.00	1.20
	39.6	128.0	BS 4825/ASME BPE	50.80	1.65
	39.6	128.0	DIN 11850 Series 2	53.00	1.50
65	-	-	EN ISO 1127/ISO 4200	-	-
	45.7	147.0	SMS 3008	63.50	1.60
	45.7	147.0	BS 4825/ASME BPE	63.50	1.65
	-	-	DIN 11850 Series 2	-	-

INLINE sensor-fitting dimensions

Clamp connection

ISO (for pipe EN ISO 1127/ISO 4200), SMS 3017/ISO 2852*
BS 4825/ASME BPE* or DIN 32676
in stainless steel (316L - 1.4404)

* Available with internal surface finish Ra = 0.8 µm

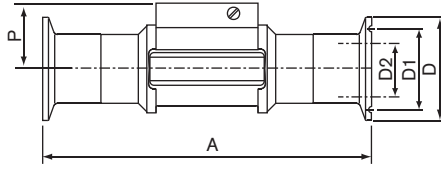

DN	P	A	Standard	D2	D1	D
[mm]	[mm]	[mm]		[mm]	[mm]	[mm]
08	-	-	ISO (for pipe EN ISO 1127/ISO 4200)	-	-	-
	-	-	SMS 3017/ISO 2852	-	-	-
	29.5	125	ASME BPE DIN 32676	10.00	27.5	34.0
15	34.5	130	ISO (for pipe EN ISO 1127/ISO 4200)	18.10	27.5	34.0
	-	-	SMS 3017/ISO 2852	-	-	-
	29.5	119	ASME BPE DIN 32676	16.00	27.5	34.0
20	32.0	150	ISO (for pipe EN ISO 1127/ISO 4200)	23.70	43.5	50.5
	-	-	SMS 3017/ISO 2852	-	-	-
	34.5	119	ASME BPE DIN 32676	15.75 20.00	19.6 27.5	25.0 34.0
25	32.2	160	ISO (for pipe EN ISO 1127/ISO 4200)	29.70	43.5	50.5
	32.0	129	SMS 3017/ISO 2852	22.60	43.5	50.5
	32.0	129	BS 4825/ASME BPE	22.10	43.5	50.5
	32.0	136	DIN 32676	26.00	43.5	50.5
32	35.8	180	ISO (for pipe EN ISO 1127/ISO 4200)	38.40	43.5	50.5
	-	-	SMS 3017/ISO 2852	-	-	-
	-	-	BS 4825/ASME BPE DIN 32676	-	-	-
40	39.6	200	ISO (for pipe EN ISO 1127/ISO 4200)	44.30	56.5	64.0
	35.8	161	SMS 3017/ISO 2852	35.60	43.5	50.5
	35.8	161	BS 4825/ASME BPE	34.80	43.5	50.5
	35.8	161	DIN 32676	38.00	43.5	50.5
50	45.7	230	ISO (for pipe EN ISO 1127/ISO 4200)	55.10	70.5	77.5
	39.6	192	SMS 3017/ISO 2852	48.60	56.5	64.0
	39.6	192	BS 4825/ASME BPE	47.50	56.5	64.0
	39.6	170	DIN 32676	50.00	56.5	64.0
65	-	-	ISO (for pipe EN ISO 1127/ISO 4200)	-	-	-
	45.7	216	SMS 3017/ISO 2852	60.30	70.5	77.5
	45.7	216	BS 4825/ASME BPE	60.20	70.5	77.5
	-	-	DIN 32676	-	-	-

Flange connection

EN1092-1 (ISO PN16), ANSI B16-5-1988 or JIS 10 K
in stainless steel (316L - 1.4404)

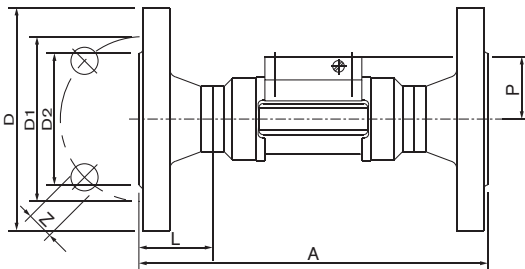

DN	P	A	Standard	L	Z	D2	D1	D
[mm]	[mm]	[mm]		[mm]	[mm]	[mm]	[mm]	[mm]
15	34.5	130	EN	23.5	4x14.0	45.0	65.0	95.0
		130	ANSI					
		152	JIS					
20	32.0	150	EN	28.5	4x14.0	58.0	75.0	105.0
		150	ANSI					
		178	JIS					
25	32.2	160	EN	28.5	4x14.0	68.0	85.0	115.0
		160	ANSI					
		216	JIS					
32	35.8	180	EN	31.0	4x18.0	78.0	100.0	140.0
		180	ANSI					
		229	JIS					
40	39.6	200	EN	36.0	4x18.0	88.0	110.0	150.0
		200	ANSI					
		241	JIS					
50	45.7	230	EN	41.0	4x18.0	102.0	125.0	165.0
		230	ANSI					
		267	JIS					

INLINE sensor-fitting dimensions

True union connection

DIN 8063, ASTM D 1785/76 or JIS K in PVC,
 DIN 16962 in PP or
 ISO 10931 in PVDF

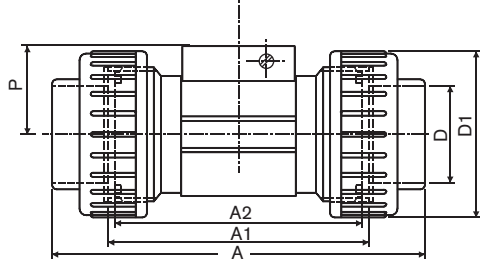

DN	P	A	Standard	A1	A2	D	D1
[mm]	[mm]	[mm]		[mm]	[mm]	[mm]	[mm]
08*	29.5	122.0 - -	DIN/ISO ASTM JIS	92 - -	90 - -	12.00 - -	- - -
15	34.5	128.0 130.0 129.0	DIN/ISO ASTM JIS	96	90	20.00 21.30 18.40	43
20	32.0	144.0 145.6 145.0	DIN/ISO ASTM JIS	106	100	25.00 26.70 26.45	53
25	32.2	160.0 161.4 161.0	DIN/ISO ASTM JIS	116	110	32.00 33.40 32.55	60
32	35.8	168.0 170.0 169.0	DIN/ISO ASTM JIS	116	110	40.00 42.20 38.60	74
40	39.6	188.0 190.2 190.0	DIN/ISO ASTM JIS	127	120	50.00 48.30 48.70	83
50	45.7	212.0 213.6 213.0	DIN/ISO ASTM JIS	136	130	63.00 60.30 60.80	103

* Only available in PVC

Spigot connection

DIN 8063 in PVC
 DIN 16962 in PP or
 ISO 10931 in PVDF

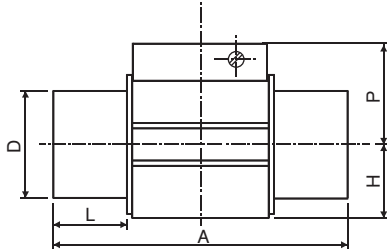

DN	P	A	Standard	L	D	H
[mm]	[mm]	[mm]		[mm]	[mm]	[mm]
15	34.5	90 85 85	DIN 8063 DIN 16962 ISO 10931	16.5 14.0 14.0	20	17.5
20	32.0	100 92 92	DIN 8063 DIN 16962 ISO 10931	20.0 16.0 16.0	25	17.5
25	32.2	110 95 95	DIN 8063 DIN 16962 ISO 10931	23.0 18.0 18.0	32	21.5
32	35.8	110 100 100	DIN 8063 DIN 16962 ISO 10931	27.5 20.0 20.0	40	27.5
40	39.6	120 106 106	DIN 8063 DIN 16962 ISO 10931	30.0 23.0 23.0	50	31.5
50	45.7	130 110 110	DIN 8063 DIN 16962 ISO 10931	37.0 27.0 27.0	63	39.5

Ordering chart for sensor-fitting S030

Port connection	Seal	Standard	Item no. DN06***-1/4"	Item no. DN06***-1/2"	Item no. DN08***-1/2"	Item no. DN15	Item no. DN20	Item no. DN25	Item no. DN32	Item no. DN40	Item no. DN50	Item no. DN 65	
Brass - with PVDF paddle wheel - Medium temperature max. 100°C, PN16													
Internal thread	FKM	G	-	-	-	423 980	423 981	423 982	423 983	423 984	423 985	-	
		NPT	-	-	-	423 986	423 987	423 988	423 989	423 990	423 991	-	
		Rc (ISO7)	-	-	-	423 992	423 993	423 994	423 995	423 996	423 997	-	
External thread	FKM	G	552 557	552 527	444 023	423 998	423 999	424 000	424 001	424 002	424 003	-	
		NPT	-	-	449 182	-	-	-	-	-	-	-	
		Rc (ISO7)	-	-	448 668	-	-	-	-	-	-	-	
Metric	FKM		-	-	16x1.5mm 552 526	-	-	-	-	-	-		
Stainless steel - with PVDF paddle wheel - Medium temperature max. 100°C, PN16													
Internal thread	FKM	G	-	-	-	424 004	424 005	424 006	424 007	424 008	424 009	-	
		NPT	-	-	-	424 010	424 011	424 012	424 013	424 014	424 015	-	
		Rc (ISO7)	-	-	-	424 016	424 017	424 018	424 019	424 020	424 021	-	
External thread	FKM	G	552 733	552 559	444 029	424 022	424 023	424 024	424 025	424 026	424 027	-	
		NPT	-	-	449 050	-	-	-	-	-	-	-	
		Rc (ISO7)	-	-	448 669	-	-	-	-	-	-	-	
	EPDM	SMS 1145	-	-	-	-	-	443 306	-	443 307	443 308	-	
Weld end	FKM	EN ISO 1127/ISO 4200	-	-	552 845 ¹⁾	424 028	424 029	424 030	424 031	424 032	424 033	-	
		EPDM	SMS 3008	-	-	-	-	-	443 298	-	443 299	443 300	443 374
		BS 4825/ASME BPE	-	-	-	-	443 369 ²⁾	443 370	443 371	443 372	443 373	443 374	
		DIN 11850 S2	-	-	551 788	551 789	551 790	551 791	-	551 792	551 793	-	
Clamp	FKM	ISO (for pipe EN ISO 1127/ISO4200)	-	-	-	424 034	424 035	424 036	424 037	424 038	424 039	-	
		EPDM	SMS 3017/ISO 2852	-	-	-	-	-	443 302	-	443 303	443 304	443 399
		SMS 3017/ISO 2852*	-	-	-	-	-	443 387	-	443 388	443 389	443 720	
		BS 4825/ASME BPE	-	-	-	-	443 395	443 396	-	443 397	443 398	443 399	
		BS 4825/ASME BPE*	-	-	-	-	443 400	443 717	-	443 718	443 719	443 720	
		DIN 32676	-	-	551 794	551 795	551 796	551 797	-	551 798	551 799	-	
Flange	FKM	EN1092-1	-	-	-	424 040	424 041	424 042	424 043	424 044	424 045	-	
		ANSI B16-5-1988	-	-	-	424 046	424 047	424 048	424 049	424 050	424 051	-	
		JIS 10K	-	-	-	430 108	430 109	430 110	430 111	430 112	430 113	-	
Stainless steel - with PVDF paddle wheel - Medium temperature max. 100°C, PN40													
Internal thr.	FKM	G	-	-	-	427 138	425 737	425 729	427 152	427 153	427 154	-	
PVC - with PVDF paddle wheel - Medium temperature max. 50°C, PN10													
True union**	FKM	DIN 8063	-	-	444 022	423 938	423 939	423 940	423 941	423 942	423 943	-	
		ASTM D 1785/76	-	-	-	423 950	423 951	423 952	423 953	423 954	423 955	-	
		JIS K	-	-	-	429 072	429 073	429 074	429 075	429 076	429 077	-	
Spigot	FKM	DIN 8063	-	-	-	423 944	423 945	423 946	423 947	423 948	423 949	-	
Extern. thr.	FKM	G	-	552 560	444 025	-	-	-	-	-	-	-	
True union** without spigot	FKM		-	-	-	430 734	430 735	430 736	430 737	430 738	430 739	-	
		EPDM	-	-	-	430 740	430 741	430 742	430 743	430 744	430 745	-	
PP - with PVDF paddle wheel - Medium temperature max. 80°C, PN10													
True union**	FKM	DIN 16962	-	-	-	423 956	423 957	423 958	423 959	423 960	423 961	-	
Spigot	FKM	DIN 16962	-	-	-	423 962	423 963	423 964	423 965	423 966	423 967	-	
PVDF - with PVDF paddle wheel - Medium temperature max. 100°C, PN10													
True union**	FKM	ISO 10931	-	-	-	423 968	423 969	423 970	423 971	423 972	423 973	-	
Spigot	FKM	ISO 10931	-	-	-	423 974	423 975	423 976	423 977	423 978	423 979	-	
Extern. thr.	FKM	ISO 10931	-	-	444 028	-	-	-	-	-	-	-	

* internal surface finish Ra = 0.8 µm

*** external thread

1) EPDM seal

2) DN20 only available in ASME BPE

Ordering chart accessories/spare parts (other versions on request)



O-ring set for plastic sensor-fitting

O-ring set for metal sensor-fitting

** depending on sensor holder version :
 - flat seal to use for holder with groove (old version)
 - O-Ring to use for holder with lug (new version and "v2")

! Two versions of the S030 in DN15 and DN20 exist, having different K factors.

Only version 2, identified by the "v2" marking, is available from March 2012. The "v2" marking can be found:

- on the bottom of the DN15 or DN20 sensor-fitting in plastic:
- on the side of the DN15 or DN20 sensor-fitting in metal:

Description	Item no.
Sensor holder	
Stainless steel with paddle wheel (PVDF), seal (FKM), screws and certificate for DN06, DN08, DN15 v2 and DN20 v2	448 678
Stainless steel with paddle wheel (PVDF), seal (FKM), screws and certificate for DN15 (except DN15 v2 and DN20 v2) to DN65	432 306
Stainless steel with paddle wheel (PVDF), seal (EPDM), screws and certificate for DN15 (except DN15 v2 and DN20 v2) to DN65	432 305
Stainless steel with paddle wheel (PVDF), seal (EPDM), screws and certificate, Ra int. = 0.8 µm for DN15 (except DN15 v2 and DN20 v2) to DN65	434 149
Stainless steel with paddle wheel (PP), seal (EPDM), screws and certificate for DN06, DN08, DN15 v2 and DN20 v2	554 896
Stainless steel with paddle wheel (PP), seal (EPDM), screws and certificate for DN15 (except DN15 v2 and DN20 v2) to DN65	449 425
Brass with paddle wheel (PVDF), seal (FKM), screws and certificate for DN06, DN08, DN15 v2 and DN20 v2	448 677
Brass with paddle wheel (PVDF), seal (FKM), screws and certificate for DN15 (except DN15 v2 and DN20 v2) to DN65	432 304
Brass with paddle wheel (PVDF), seal (EPDM), screws and certificate for DN15 (except DN15 v2 and DN20 v2) to DN65	432 303
Brass with paddle wheel (PP), seal (EPDM), screws and certificate for DN15 (except DN15 v2 and DN20 v2) to DN65	449 866
PVC with paddle wheel (PVDF), seal (FKM), screws and certificate for DN06, DN08, DN15 v2 and DN20 v2	448 674
PVC with paddle wheel (PVDF), seal (FKM), screws and certificate for DN15 (except DN15 v2 and DN20 v2) to DN65	432 298
PVC with paddle wheel (PVDF), seal (EPDM), screws and certificate for DN15 (except DN15 v2 and DN20 v2) to DN65	432 297
PVC with paddle wheel (PP), seal (EPDM), screws and certificate for DN15 (except DN15 v2 and DN20 v2) to DN65	443 982
PP with paddle wheel (PVDF), seal (FKM), screws and certificate for DN15 to DN65	432 300
PP with paddle wheel (PVDF), seal (EPDM), screws and certificate for DN15 to DN65	432 299
PP with paddle wheel (PP), seal (FKM), screws and certificate for DN15 to DN65	552 881
PP with paddle wheel (PP), seal (EPDM), screws and certificate for DN15 to DN65	443 983
PVDF with paddle wheel (PVDF), seal (FKM), screws and certificate for DN06, DN08, DN15 v2 and DN20 v2	448 676
PVDF with paddle wheel (PVDF), seal (FKM), screws and certificate for DN15 (except DN15 v2 and DN20 v2) to DN65	432 302
PVDF with paddle wheel (PVDF), seal (EPDM), screws and certificate for DN15 (except DN15 v2 and DN20 v2) to DN65	432 301
O-ring set	
FKM - for metal sensor-fitting, DN06 to DN65	426 340
EPDM - for metal sensor-fitting, DN06 to DN65	426 341
FKM - for plastic sensor-fitting, DN08	448 679
FKM - for plastic sensor-fitting, DN15	431 555
FKM - for plastic sensor-fitting, DN20	431 556
FKM - for plastic sensor-fitting, DN25	431 557
FKM - for plastic sensor-fitting, DN32	431 558
FKM - for plastic sensor-fitting, DN40	431 559
FKM - for plastic sensor-fitting, DN50	431 560
EPDM - for plastic sensor-fitting, DN08	448 680
EPDM - for plastic sensor-fitting, DN15	431 561
EPDM - for plastic sensor-fitting, DN20	431 562
EPDM - for plastic sensor-fitting, DN25	431 563
EPDM - for plastic sensor-fitting, DN32	431 564
EPDM - for plastic sensor-fitting, DN40	431 565
EPDM - for plastic sensor-fitting, DN50	431 566

Ordering chart accessories/spare parts (other versions on request)

Description	Item no.
Approvals/Certificates	
3.1 certificate	440 790
2.2 certificate	440 789
Surface finish certificate	444 898
3 points calibration certificate	550 676
FDA approval	449 788

Interconnection possibilities with the S030

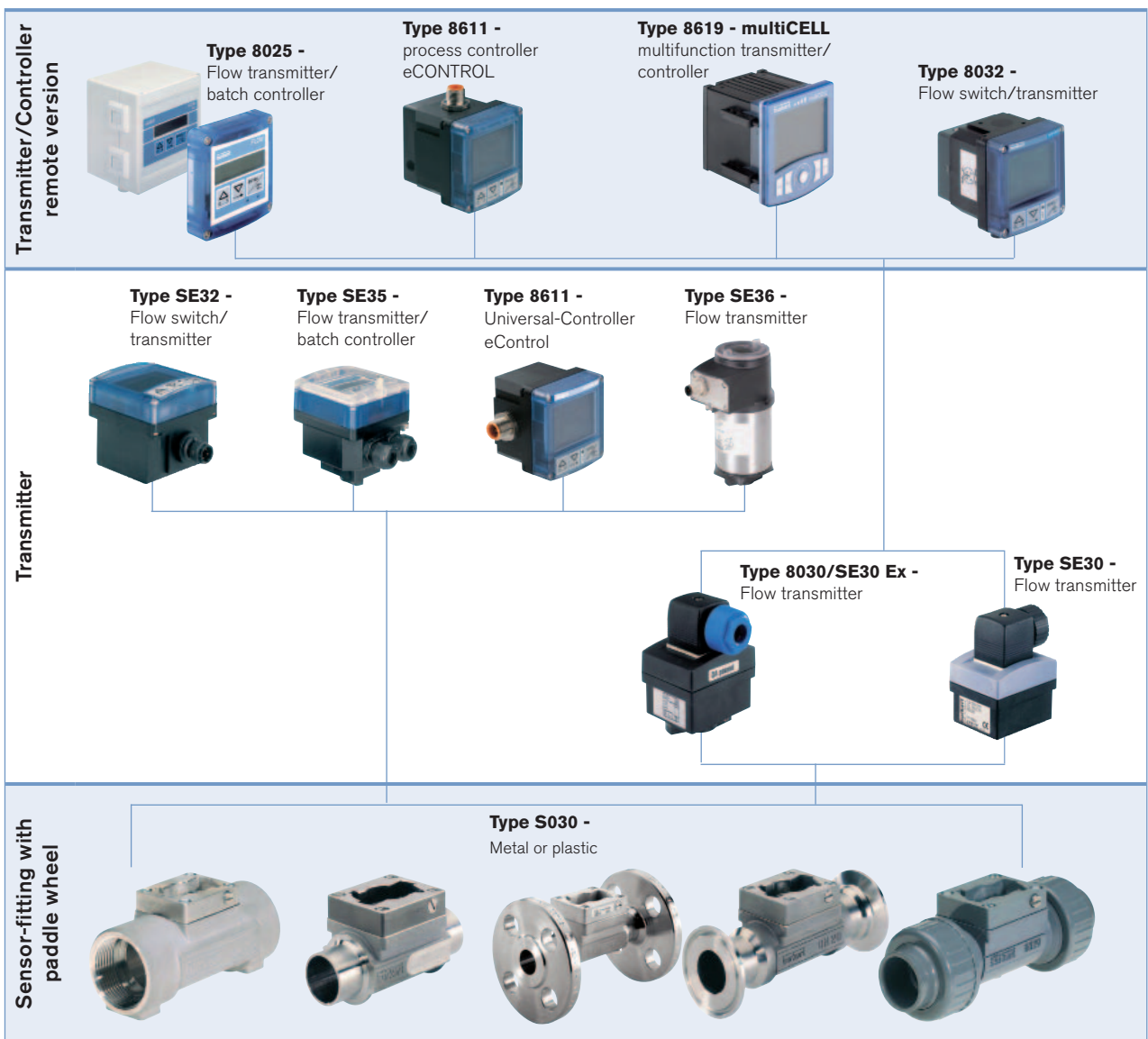

To find your nearest Bürkert office, click on the orange box →

www.burkert.com

In case of special application conditions, please consult for advice.

Subject to alteration.
© Christian Bürkert GmbH & Co. KG

1401/11_EU-en_00891878