

Raccordi per Pompe

Pump
Connectors



Officine Meccaniche

ciocca s.r.l.

OFFICINE MECCANICHE CIOCCA s.r.l.
24053 Brignano Gera D'Adda (Bg) - Italy - Via Treviglio, 44
Tel. 0363.382345 - 815504 (2 linee r.a.) - Telefax 0363.815333
Web Site: www.cioccasrl.it - e.mail: info@cioccasrl.it

ENTER

LAVORAZIONI MECCANICHE - FLANGE S.A.E. E CETOP - VALVOLE A SFERA

RAGGORDI POMPA DRITTI

Straight pump connector
Raccord droit pour pompe
Flanschanschluß gerade

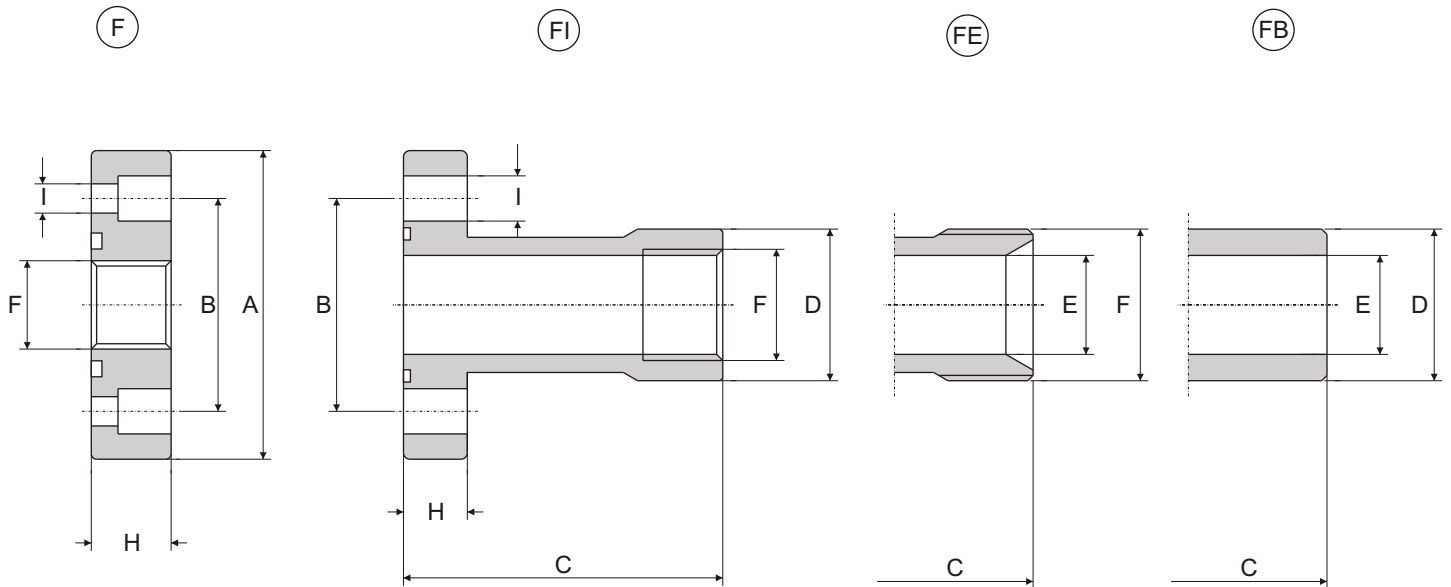

F = Flangia / Flange / Bride / Flansch

FI = Raccordo dritto con filettatura interna / Straight connector with internal thread / Raccord droit taraude femelle / Einschraubflansch

FE = Raccordo dritto con filettatura esterna / Straight connector with external thread / Raccord droit taraude mâle / Außengewindeflansch

FB = Raccordo dritto / Straight flange / Raccord droit / Flansch

Tipo Type	Gruppo pompa Pump group	A	B	C	D	E	F	H	I	N. fori N. Holes	Viti Bolts	OR O-RING
F	1	45	30	-	-	-	3/8"	13	6,5	4	M 6 x 16	2075
FI	1	45	30	55	21	-	3/8"	10	6,5	4	M 6 x 20	2075
FE	1	45	30	55	-	14	1/2"	10	6,5	4	M 6 x 20	2075
FB	1	45	30	55	19	14	-	10	6,5	4	M 6 x 20	2075
F	2	58	40	-	-	-	1/2"	15	8,5	4	M 8 x 20	2100
FI	2	58	40	60	26,5	-	1/2"	12	8,5	4	M 8 x 25	2100
FE	2	58	40	60	-	19	3/4"	12	8,5	4	M 8 x 25	2100
FB	2	58	40	60	25,4	19	-	12	8,5	4	M 8 x 25	2100
F	3/A	75	51	-	-	-	3/4"	18	10,5	4	M10 x 25	3125
FI	3/A	76	51	72	33,5	-	3/4"	16	10,5	4	M10 x 35	3125
FE	3/A	76	51	72	-	24	1"	16	10,5	4	M10 x 35	3125
FB	3/A	76	51	72	32	24,5	-	16	10,5	4	M10 x 35	3125
F	3/B	75	56	-	-	-	3/4"	18	10,5	4	M10 x 25	3125
FI	3/B	76	56	72	33,5	-	3/4"	16	10,5	4	M10 x 35	3125
FE	3/B	76	56	72	-	24	1"	16	10,5	4	M10 x 35	3125
FB	3/B	76	56	72	32	24,5	-	16	10,5	4	M10 x 35	3125
F	3,5/A	88	62	-	-	-	1"	20	10,5	4	M10 x 25	144
F	3,5/B	88	62	-	-	-	1"	20	12,5	4	M12 x 25	144
F	4	98	72,5	-	-	-	1" 1/4	22	12,5	4	M12 x 30	4187

Costruiti in acciaio, questi raccordi e flange permettono di collegare i tubi di aspirazione o mandata sulle pompe oleodinamiche evitando perdite di carico dovute a raccordi a gomito. Sono forniti completi di viti ed o-ring (vedi tabella) e rondelle Grower.

Straight flanges made of steel which allow the connection of rigid tubes to the inlet or outlet ports of hydraulic pumps. They're supplied complete with screws, o-ring (see schedule) and expansion washers.

Ces raccords sont fait en acier. Ils permettent de relier les tubes d'entrée et sortie sûr les pompés oleodinamiques et ils évitent les pertes de charge causees par les raccords coude. Ils sont vendues avec vis, rondelles et OR.

Gerade Anschlüsse aus Stahl zur Verbindung der Saug- und Druckschläuche mit Universal-Zahnradpumpen. Einschließlich Schrauben, Federringen und O-Ringen (Siehe Tabelle)

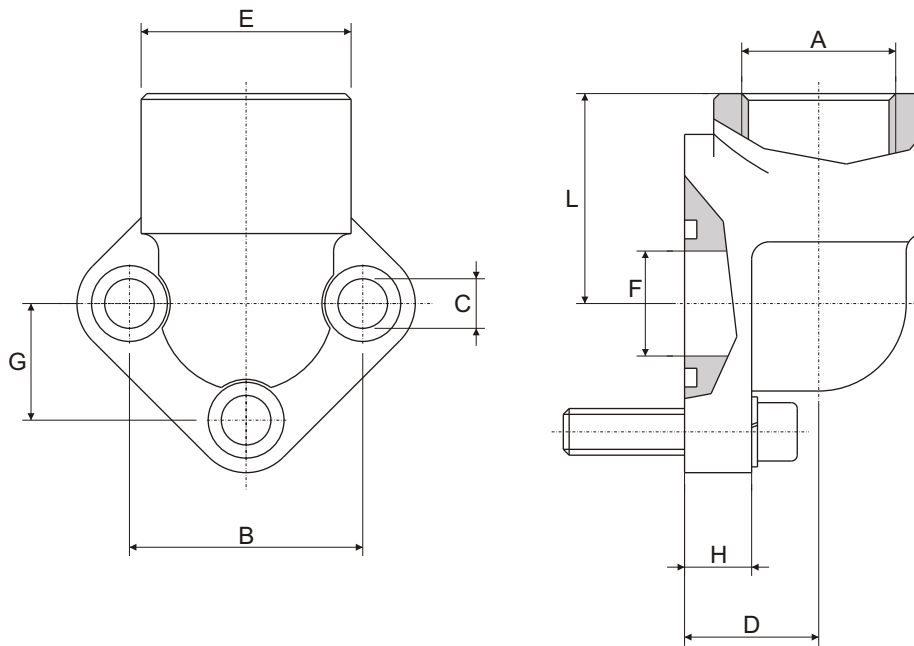

Costruiti in acciaio, sono adatti per il montaggio su pompe e motori oleodinamici. A richiesta si eseguono anche a saldare di tasca.

These elbow joints are made of steel. They are supplied complete with screws. On request we also produce it socket welding.

Ils sont fait en acier et ils sont apte pour être montés sur pompes et moteurs oleodinamiques. Sur demand à emmanchement.

Hergestellt aus Stahl. Sie sind für die Montage von Pumpen und Hydraulicmotoren geeignet. Auf anfrage auch als schweissflansch

Tipo Type	Gruppo pompa Pump group	B	G	C	E	A	L	F	H	D	N. fori N. Holes	Viti Bolts	OR O-RING
RPA 0,5/38 RPA 0,5/12	0,5	26	13	5,5	30	$\frac{3}{8}$ " $\frac{1}{2}$ "	31	11	9	17	3	M 5 x 18	2056
RPA 1/38 RPA 1/12	1	30	15	6,5	30	$\frac{3}{8}$ " $\frac{1}{2}$ "	31	12	9	17	3	M 6 x 20	121
RPA 2/12 RPA 2/34	2	40	20	8,5	36	$\frac{1}{2}$ " $\frac{3}{4}$ "	36	19	11,5	23	3	M 8 x 25	132
RPA 3/34/A RPA 3/100/A	3	51	25,5	10,5	45	$\frac{3}{4}$ " 1"	46	24	13	26	3	M10 x 30	4118
RPA 3/34/B RPA 3/100/B	3	56	28	10,5	45	$\frac{3}{4}$ " 1"	46	24	13	26	3	M10 x 30	4118
RPA 3,5 114/A RPA 3,5 100/A	3,5	62	31	11	55	1" $\frac{1}{4}$ " 1"	55	31 25	14	35	3	M10 x 30	4150
RPA 3,5 114/B RPA 3,5 100/B	3,5	62	31	13	55	1" $\frac{1}{4}$ " 1"	55	31 25	14	35	3	M12 x 35	4150
RPA 4/112 RPA 4/114	4	72,5	36,2	13	62	1" $\frac{1}{2}$ " 1" $\frac{1}{4}$ "	58	38 31	15	38	3	M12 x 35	4187

Per ordinazione flange: / Ordering Examples: / Pour commander brides: / Bestellbeispiel für Flansche:

Solo flangia.....RPA...
Only flange.....RPA...
Seulement bride...RPA...
Nur Flansch.....RPA...

Flangia completa di viti metriche, rondelle e OR.....RPA...M
Complete flange with metric screws, washers and o-ring.....RPA...M
Bride complete des vis métriques, rondelles et OR.....RPA...M
Flansch einschl. metrischen Zylinderschrauben, Federringen und O-Ring..RPA...M

RAGCORDO DRITTO PER POMPA

con attacco DIN 2353

Pump connector according
to DIN 2353
Raccord droit pour pompe taraudé
métrique DIN 2353
Pumpenanschluss nach DIN 2353

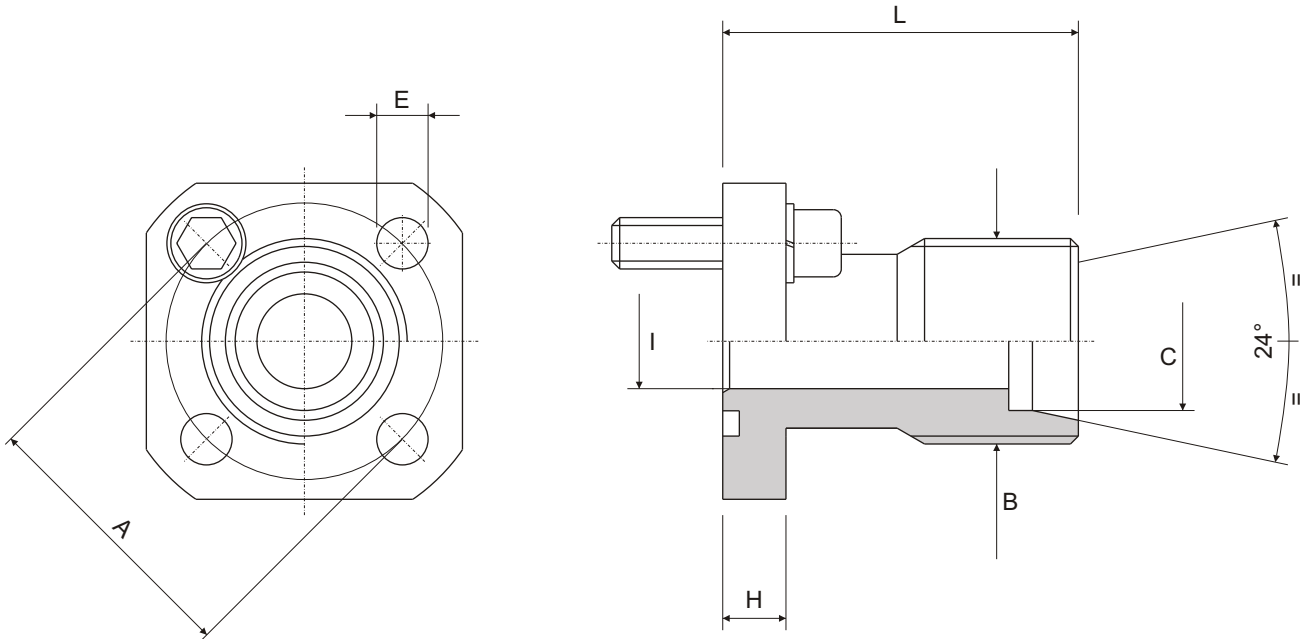

Pressione max esercizio bar	Tipo Type	A	B	C	E	H	I	L	M viti / bolts	OR O-RING
315	RD 35-10 L	35	M16 x 1,5	10	6,5	8	8	30	6 x 20	3075
315	RD 35-12 L		M18 x 1,5	12			10			
250	RD 35-15 L		M22 x 1,5	15			12			
315	RD 35-16 S		M24 x 1,5	16			12			
100	RD 40-15 L	40	M22 x 1,5	15	6,5	8	12	35	6 x 20	3100
100	RD 40-18 L		M26 x 1,5	18			15			
100	RD 40-22 L		M30 x 2	22			19			
100	RD 40-28 L		M36 x 2	28			19			
250	RD 40-20 S		M30 x 2	20			16			
250	RD 55-20 S	55	M30 x 2	20	8,5	12	16	50	8 x 25	3125
250	RD 55-25 S		M36 x 2	25			20			
250	RD 55-30 S		M42 x 2	30			26			
100	RD 55-35 L		M45 x 2	35			26			

Per ordinare raccordiRD...M
How to order connectorsRD...M
Pour commanderRD...M
Bestellbeispiel für AnschlussRD...M

La misura "C" può essere variata a seconda delle esigenze del cliente.
Measurement "C" can be changed according to customer's requests.
La mesure "C" peut être changé selon les exigences de la clientèle.
Auch für andere abmessungen "C" nach vorgabe Lieferbar.

RACCORDO A 90° PER POMPA con attacco DIN 2353

**90° Pump connector
according to DIN 2353**
Raccord à 90° taraudé métrique DIN 2353
90° Pumpenanschluss nach DIN 2353

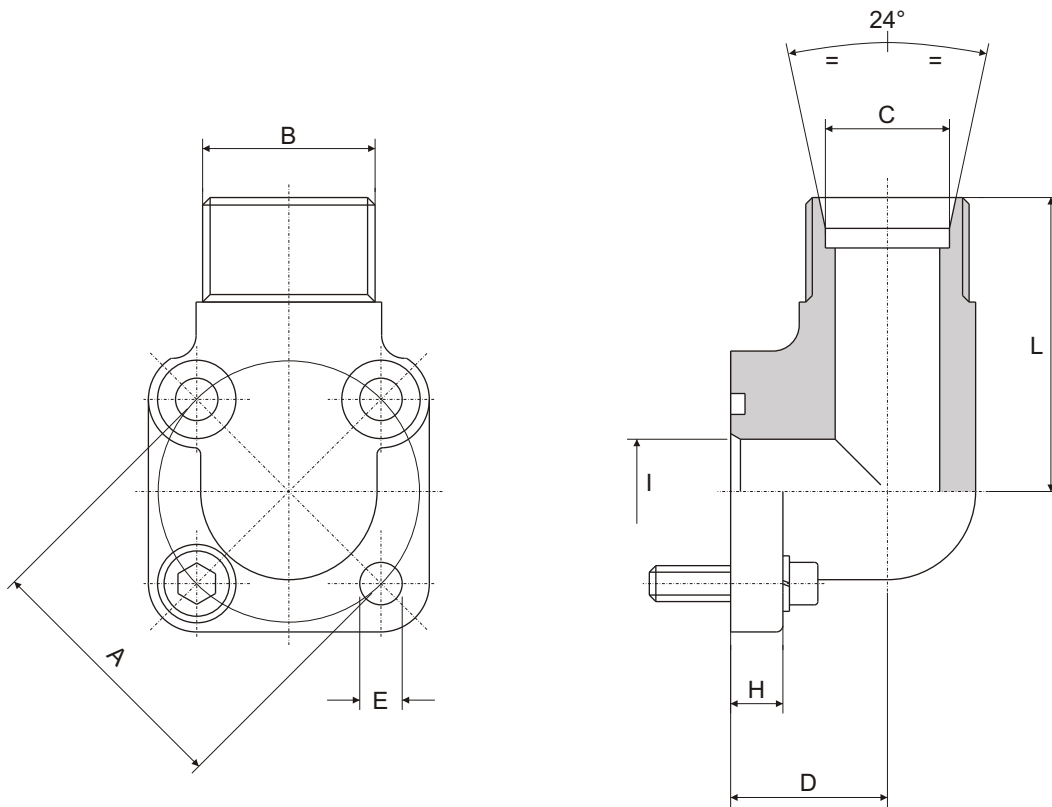

Pressione max esercizio bar	Tipo Type	A	B	C	D	E	H	I	L	M Viti / Bolts		OR O-RING
										N. 2	N. 2	
315	R 35-10 L-90°	35	M16 x 1,5	10	16,5	6,5	8	8	38	6 x 20	6 x 35	3075
315	R 35-12 L-90°		M18 x 1,5	12	16,5			10			6 x 35	
250	R 35-15 L-90°		M22 x 1,5	15	16,5			12			6 x 35	
315	R 35-16 S-90°		M24 x 1,5	16	20			12			6 x 40	
100	R 40-15 L-90°	40	M22 x 1,5	15	22,5	6,5	8	12	38	6 x 20	6 x 40	3100
100	R 40-18 L-90°		M26 x 1,5	18	22,5			15			6 x 40	
100	R 40-22 L-90°		M30 x 2	22	22,5			18			6 x 40	
100	R 40-28 L-90°		M36 x 2	28	28			18			6 x 50	
250	R 40-20 S-90°		M30 x 2	20	22,5			16			6 x 40	
100	R 55-35 L-90°	55	M45 x 2	35	31	8,5	12	26	49	8 x 25	8 x 60	3125
250	R 55-20 S-90°		M30 x 2	20	24			16			8 x 45	
250	R 55-25 S-90°		M36 x 2	25	31			20			8 x 60	
250	R 55-30 S-90°		M42 x 2	30	31			26			8 x 60	
100	R 55-42 L-90°		M52 x 2	42	40			26			8 x 70	
250	R 55-38 S-90°		M52 x 2	38	40			26			8 x 70	

Per ordinare raccordi R...M
How to order connectors R...M
Pour commander R...M
Bestellbeispiel für Anschluss R...M

La misura "C" può essere variata a seconda delle esigenze del cliente.
Measurement "C" can be changed according to customer's requests.
La mesure "C" peut être changé selon les exigences de la clientèle.
Auch für andere abmessungen "C" nach vorgebe Lieferbar.

RACCORDO A 90° PER POMPA con attacco GAS

90° Pump connector BSP threaded
Raccord à 90° tauradé BSP
90° Pumpenanschluss mit gewinde

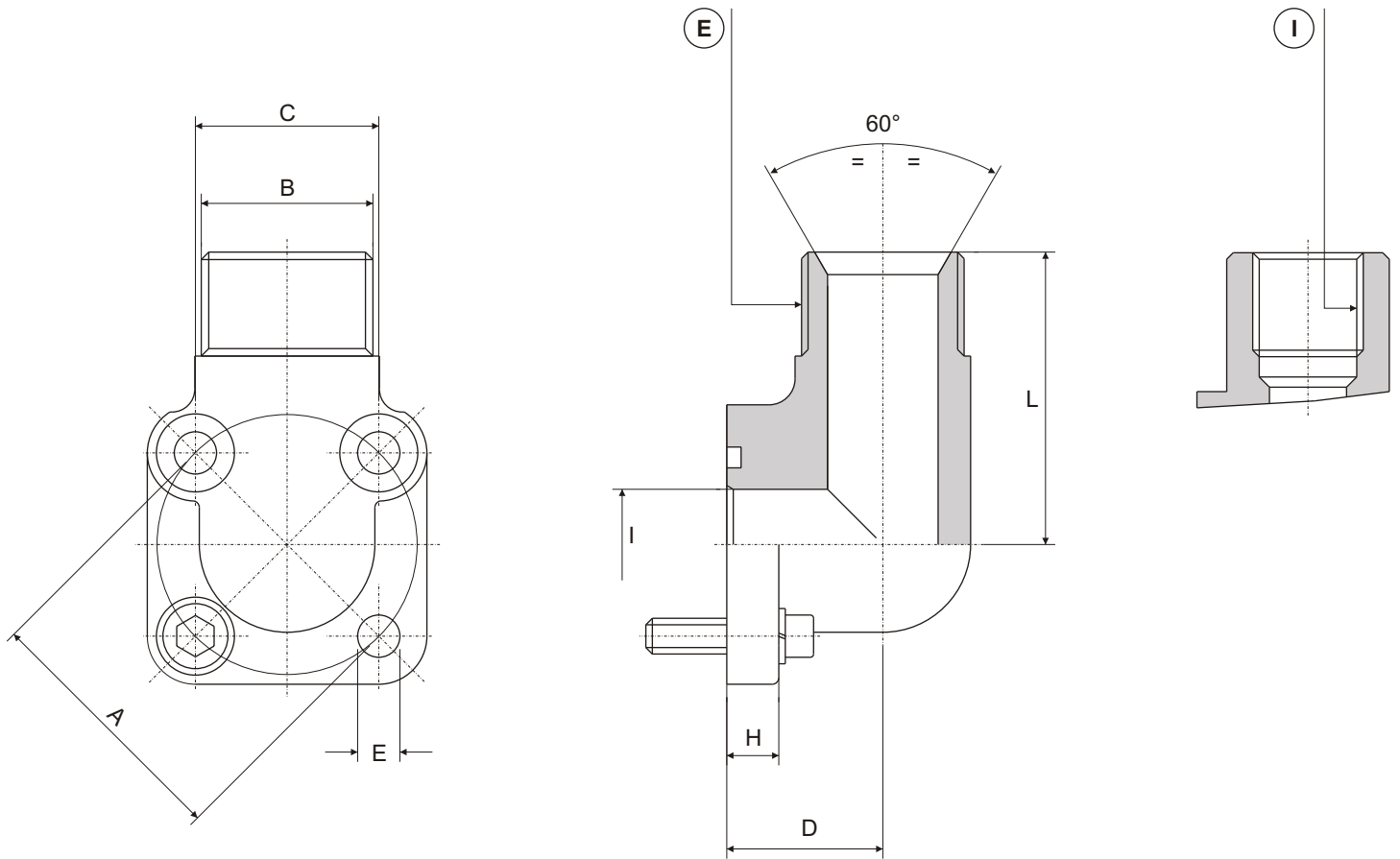

Pressione max esercizio bar	Tipo Type	A	B	C	D	E	H	I	L	M Viti / Bolts		OR O-RING
										N. 2	N. 2	
315	R 35-90°-3/8"	35	3/8"	24,8	16,5	6,5	8	10	38	6 x 20	6 x 35	3075
	R 35-90°-1/2"		1/2"		16,5			12			6 x 35	
	R 35-90°-3/4" *		3/4"		20			15			6 x 40	
250	R 40-90°-3/8"	40	3/8"	28,2	22,5	6,5	8	10	38	6 x 20	6 x 40	3100
	R 40-90°-1/2"		1/2"		22,5			12			6 x 40	
	R 40-90°-3/4"		3/4"		22,5			17			6 x 40	
	R 40-90°-1" *		1"		28			19			6 x 50	
250	R 55-90°-1/2"	55	1/2"	38,8	24	8,5	12	12	46	8 x 25	8 x 45	3125
	R 55-90°-3/4"		3/4"		31			17			8 x 60	
	R 55-90°-1"		1"		31			22			8 x 70	

* Solo tipo "E" / Only "E" type / Seulement tipe "E" / Nur "E"

Per ordinare raccordi R...E / R...I
How to order connectors R...E / R...I
Pour commander R...E / R...I
Bestellbeispiel für Anschluss R...E / R...I

La misura "B" può essere variata a seconda delle esigenze del cliente.
Measurement "B" can be changed according to customer's requests.
La mesure "B" peut être changé selon les exigences de la clientèle.
Auch für andere abmessungen "B" nach vorgabe Lieferbar.

RACCORDO A 90° A SALDARE DI TASCA

Socket weld 90° connector
Raccord à 90° à emmanchement
Einschweiss-Winkelflansch 90°

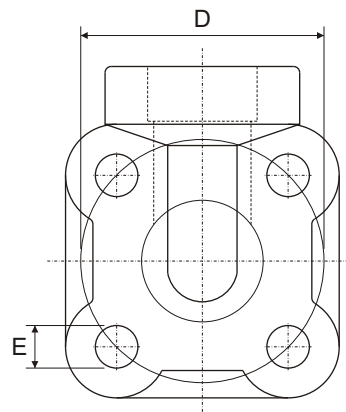
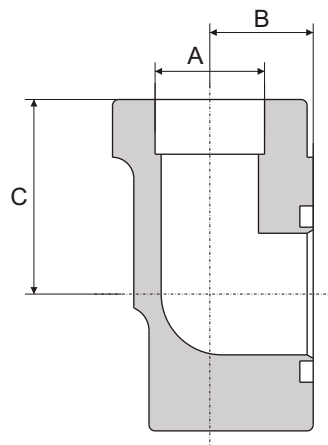

tipo A

Tipo Type	A	B	C	D	E	B Viti / Bolts	OR O-RING
F-30-12-90°-SA	12						
F-30-14-90°-SA	14						
F-30-16-90°-SA	16	13	27	30	6,5	6 x 30	121
F-30-18-90°-SA	18						
F-35-14-90°-SA	14	12					
F-35-16-90°-SA	16						
F-35-18-90°-SA	18	14	30	35	6,5	6 x 35	3075
F-35-20-90°-SA	20						
F-40-18-90°-SA	18						
F-40-20-90°-SA	20						
F-40-22-90°-SA	22	17	32	40	6,5	6 x 40	132
F-40-25-90°-SA	25						

tipo B

Tipo Type	A	B	C	D	E	B Viti / Bolts	OR O-RING
F-30-12-90°-SB	12						
F-30-14-90°-SB	14	13	27	30	8,5	8 x 35	121
F-30-16-90°-SB	16						
F-35-14-90°-SB	14						
F-35-16-90°-SB	16	14	30	35	8,5	8 x 40	3075
F-35-18-90°-SB	18						
F-40-18-90°-SB	18						
F-40-20-90°-SB	20						
F-40-22-90°-SB	22	17	32	40	8,5	8 x 40	132
F-40-25-90°-SB	25						

Per ordinare raccordi a 90°.....F..A / F..B
How to order 90° connectors.....F..A / F..B
Pour commander.....F..A / F..B
Bestellbeispiel für Anschluss.....F..A / F..B

La misura "A" può essere variata a seconda delle esigenze del cliente.
Measurement "A" can be changed according to customer's requests.
La mesure "A" peut être changé selon les exigences de la clientèle.
Auch für andere abmessungen "A" nach vorgabe Lieferbar.

RACCORDO ALLUMINIO 90° SERIE RPB

RPB Connectors

Raccord RPB

Gewinde-Winkelflansch RPB Werkstoff: Aluminium

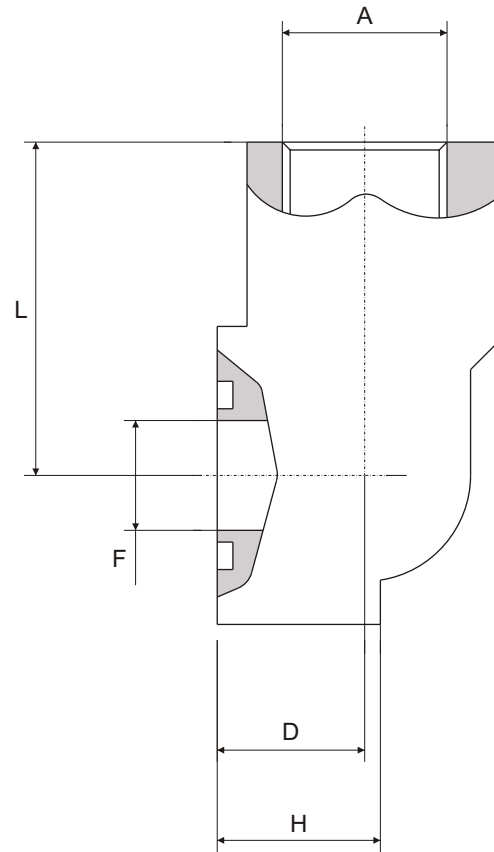
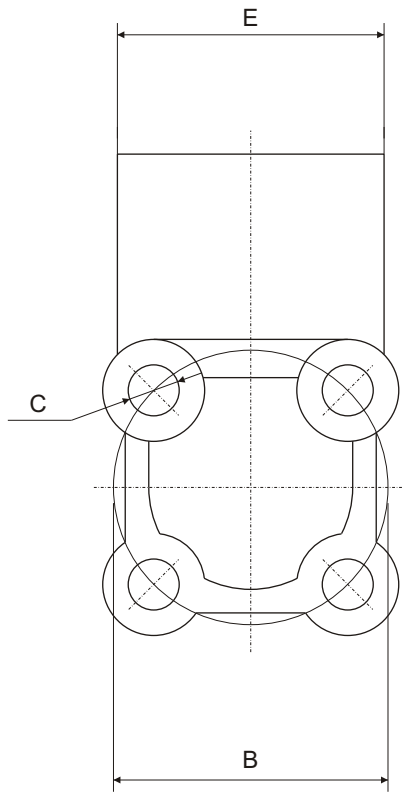

Pressione max esercizio bar	Tipo Type	Taglia Size	A BSP	B	C	D	E	F	H	L	N. Fori Holes	Viti / Bolts	OR O-RING
180	RPB 38 - 30	30	3/8"	30	6,5	18	33	11,5	20	39	4	M 6 x 30-M 6 x 40	121
	RPB 12 - 30	30	1/2"	30	6,5	18	33	11,5	20	39	4	M 6 x 30-M 6 x 40	121
180	RPB 38 - 35	35	3/8"	35	6,5	18	34	14	20	42,5	4	M 6 x 30-M 6 x 40	3075
	RPB 12 - 35	35	1/2"	35	6,5	18	34	14	20	42,5	4	M 6 x 30-M 6 x 40	3075
180	RPB 12 - 40	40	1/2"	40	6,5	24	41	18	28	47,5	4	M 6 x 40-M 6 x 50	130
	RPB 34 - 40	40	3/4"	40	6,5	24	41	18	28	47,5	4	M 6 x 40-M 6 x 50	130
180	RPB 34 - 55	55	3/4"	55	8,5	29	49	24,5	31	54	4	M 8 x 45-M 8 x 60	4118
	RPB 100 - 55	55	1"	55	8,5	29	49	24,5	31	54	4	M 8 x 45-M 8 x 60	4118

Per ordinare RPB...
Ordering examples RPB...

Pour commander RPB...
Bestellbeispiel RPB...

Costruiti in alluminio, sono adatti per il montaggio su pompe e motori oleodinamici. Vengono forniti completi di viti ed o-ring e rondelle Schnorr.

These elbow joints are made of aluminium. They are supplied complete with screws, o-ring and Schnorr washers.

Ils sont fait en aluminium et ils sont apte pour être montés sûr pompe et moteurs oleodinamiques. Ils sont vendu avec vis, OR et rondelles schnorr.

Hergestellt aus Aluminium. Sie sind für die Montage von Pumpen und Hydraulikmotoren geeignet. Ausgerüstet mit Schrauben, OR und Schnorr-Ringen.

RAGCORDO ALLUMINIO 90° SERIE RAP

RAP Connectors
Raccord RAP

Gewinde-Winkelflansch RAP Werkstoff: Aluminium

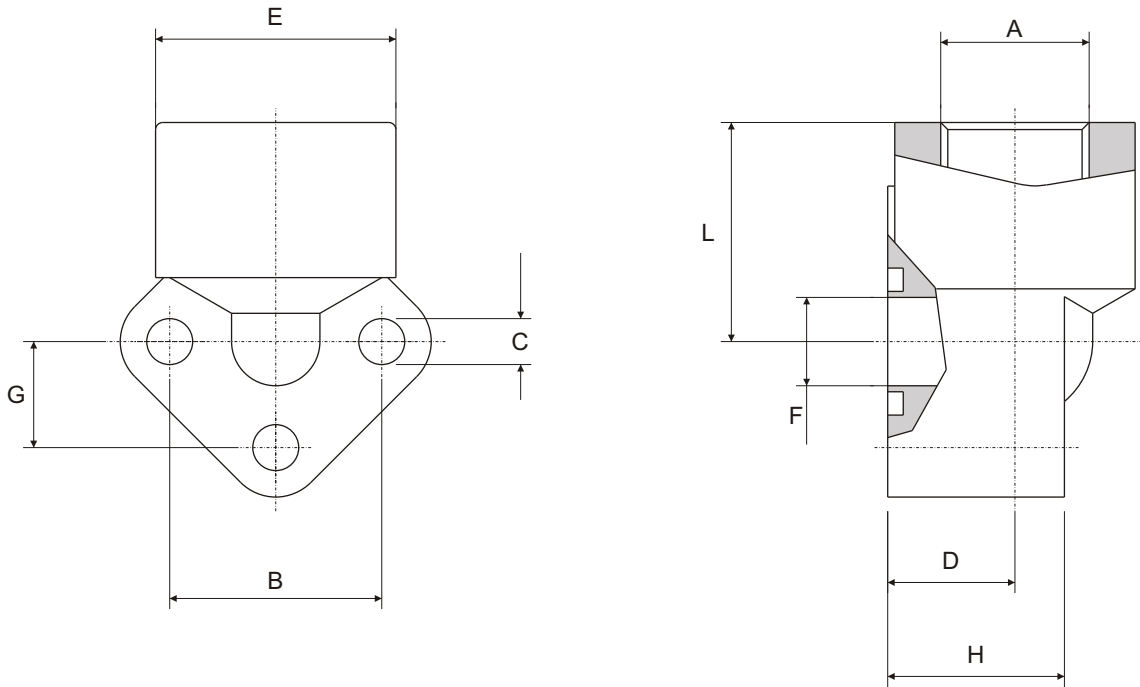

Pressione max esercizio bar	Tipo Type	Gruppo pompa Pump size	A BSP	B	C	D	E	F	G	H	L	N. Fori Holes	Viti / Bolts	OR O-RING
180	RAP 05 - 38	05	3/8"	26	5,5	18	31	10	13	25	31	3	M 5 x 35	2056
	RAP 05 - 12	05	1/2"	26	5,5	18	31	10	13	25	31	3	M 5 x 35	2056
180	RAP 1 - 38	1	3/8"	30	6,5	18	34	12,5	15	26	31	3	M 6 x 35	121
	RAP 1 - 12	1	1/2"	30	6,5	18	34	12,5	15	26	31	3	M 6 x 35	121
180	RAP 2 - 12	2	1/2"	40	8,5	21,5	42	18	20	31	40	3	M 8 x 45	130
	RAP 2 - 34	2	3/4"	40	8,5	21,5	42	18	20	31	40	3	M 8 x 45	130
180	RAP 3 - 34	3	3/4"	51-56	11	26	49	24,5	25,5-28	42	46	3	M10 x 60	4118
	RAP 3 - 100	3	1"	51-56	11	26	49	24,5	25,5-28	42	46	3	M10 x 60	4118

Per ordinareRAP..
Ordering examplesRAP..

Pour commanderRAP..
BestellbeispielRAP..

Costruiti in alluminio, sono adatti per il montaggio su pompe e motori oleodinamici. Vengono forniti completi di viti ed o-ring e rondelle Schnorr.

These elbow joints are made of aluminium. They are supplied complete with screws, o-ring and Schnorr washers.

Ils sont fait en aluminium et ils sont apte pour être montés sûr pompe et moteurs oleodynamiques. Ils sont vendu avec vis, OR et rondelles schnorr.

Hergestellt aus Aluminium. Sie sind für die Montage von Pumpen und Hydraulikmotoren geeignet. Ausgerüstet mit Schrauben, OR und Schnorr-Ringen.