



Description:

EDS 8000 is an electronic pressure switch in compact design which is simple to adjust.

Models with one or two transistor switch outputs (PNP or NPN) are available.

The switch points are set using the two keys and a four-digit display. During operation the switch position is indicated by either a red or a green backlight in the display.

For optimum adaptation to a particular application, the instrument has many additional adjustment parameters, e.g. switching delay times, N/O / N/C function of the outputs.

EDS 8000 is available in various pressure ranges between 0 .. 25 bar and 0 .. 600 bar.

The main applications of the EDS 8000 are to indicate pressures and limits in hydraulics and pneumatics, or any application where high switching frequency or consistent switching accuracy would overburden a mechanical pressure switch.

Special features:

- Menu navigation according to VDMA
- 1 or 2 PNP transistor switching outputs
- Robust stainless steel measurement cell
- Accuracy class $\leq \pm 1\%$ FS
- 4-digit display
- Multi-colour switch display
- Protection class IP 67
- Simple operation with key programming
- Many useful additional functions

Electronic Pressure Switch EDS 8000

Technical data:

Input data

Measurement range	25; 40; 100; 250; 400; 600 bar	
Overload pressures	80; 80; 200; 500; 800; 1000 bar	
Burst pressures	200; 200; 500; 1000; 2000; 2000 bar	
Mechanical connection	G $\frac{1}{4}$ A DIN 3852; Form E	
Torque value	20 Nm	
Parts in contact with medium	Mech. conn.:	Stainless steel
	Sensor cell:	Thin-film strain gauge
	Seal:	FPM

Output data

Accuracy to DIN 16086	$\leq \pm 0.5\%$ FS typ.	
Max. setting (display)	$\leq \pm 1\%$ FS max.	
Repeatability	$\leq \pm 0.5\%$ FS max.	
Temperature drift (environment)	$\leq \pm 0.03\%$ FS / °C max. zero point	
	$\leq \pm 0.03\%$ FS / °C max. range	
Long-term stability	$\leq \pm 0.25\%$ FS / year max.	

Switch outputs

Type	1 or 2 transistor switching outputs PNP or NPN
Switching current	max. 250 mA per output
Switching cycles	> 100 million
Reaction time	< 10 ms

Environmental conditions

Compensated temperature range	-25 .. + 85 °C
Ambient temperature range ¹⁾	-40 .. +100 °C / -25 °C +100 °C
Storage temperature range	-40 .. + 85 °C
Fluid temperature range ¹⁾	-40 .. +125 °C / -25 .. +125 °C
Nominal temperature range of display (read-out)	-15 .. 70 °C
CE mark	EN 61000-6-1 / 2 / 3 / 4
UL mark ²⁾	Certificate No. E318391
Vibration resistance to DIN EN 60068-2-6 (0 .. 500 Hz)	approx. 10 g
Shock resistance to DIN EN 60068-2-29 (11 ms)	approx. 50 g
Protection class to IEC 60529	IP 67 (when an IP 67 connector is used)

Other data

Supply voltage	9.6 .. 32 V DC
for use acc. to UL spec.	- limited energy - according to 9.3 UL 61010; Class 2; UL 1310/1585; LPS UL 60950
Current consumption	max. 0.535 A total max. 35 mA (with inactive switch output)
Display	4-digit, LED, 7 segment, height of digits 4.5 mm
Life expectancy	> 10 million cycles (0 .. 100 %)
Weight	~ 70 g

Note: Reverse polarity protection of the supply voltage, excess voltage, override and short circuit protection are provided.

FS (Full Scale) = relative to the complete measurement range

¹⁾ -25 °C with FPM seal, -40 °C on request

²⁾ Environmental conditions according to 1.4.2 UL 61010-1; C22.2 No 61010-1

Setting options:

All the terms and symbols used for setting the EDS 8000 as well as menu structure comply with the specifications of the German Engineering Federation Standard (VDMA 24574-1) for pressure switches. The EDS 8000 is easy and convenient to set up using the two buttons.

Setting ranges for the switch outputs:

Meas. range in bar	Lower limit of RP / FL in bar	Upper limit of SP / FH in bar
0 .. 25	0.25	25.00
0 .. 40	0.4	40.0
0 .. 100	1.0	100.0
0 .. 250	2.5	250.0
0 .. 400	4	400
0 .. 600	6	600

Meas. range in bar	Min. difference betw. RP & SP and FL & FH	Increment* in bar
0 .. 25	0.25	0.05
0 .. 40	0.4	0.1
0 .. 100	1.0	0.2
0 .. 250	2.5	0.5
0 .. 400	4	1
0 .. 600	6	1

* All ranges given in the table are adjustable by the increments shown.
 SP = Switching point
 RP = Switch-back point
 FL = Pressure window lower value
 FH = Pressure window upper value

Additional functions:

- Switching mode of the switching outputs adjustable (switching point function or window function)
- Switching direction of the switching outputs adjustable (N/C or N/O function)
- Switch-on and switch-off delay adjustable from 0.00 .. 99.99 seconds
- Display filter for smoothing the display value during pressure pulsations
- Pressure can be displayed in bar, psi, MPa

Pin connections:

M12x1, 4 pole

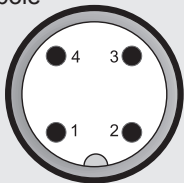

Pin	EDS 8446-1	EDS 8446-2
1	+U _B	+U _B
2	n.c.	SP 2
3	0 V	0 V
4	SP 1	SP 1

Model code:

EDS 8 4 4 6 - X - XXXX - X00

Mechanical connection

4 = G1/4 A DIN 3852 (male)

Electrical connection

6 = Male M12x1, 4 pole
(connector not supplied)

Output

1 = 1 switching output
 2 = 2 switching outputs

Pressure ranges in bar

0025; 0040; 0100; 0250; 0400; 0600

Modification number

000 = Standard
 N00 = Version with NPN switching outputs

Note:

On instruments with a different modification number, please read the label or the technical amendment details supplied with the instrument.

Accessories:

Appropriate accessories, such as electrical connectors, mechanical adapters, etc, can be found in the Accessories brochure.

Dimensions:

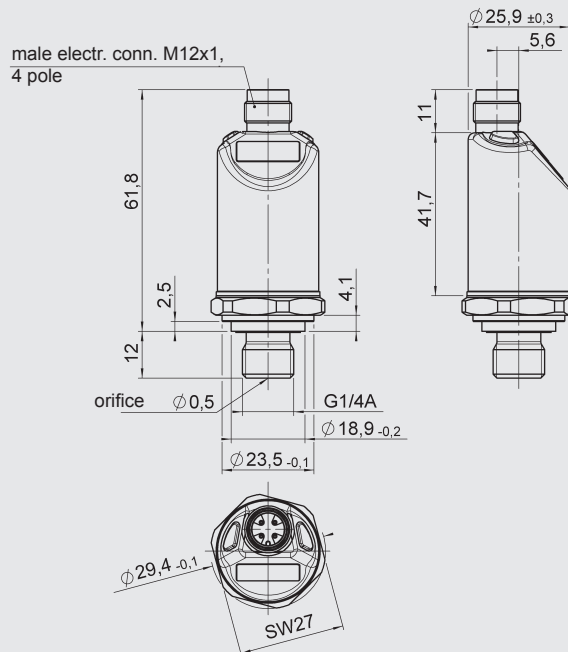

Note:

The information in this brochure relates to the operating conditions and applications described. For applications or operating conditions not described, please contact the relevant technical department. Subject to technical modifications.

HYDAC ELECTRONIC GMBH

Hauptstraße 27, D-66128 Saarbrücken
 Telephone +49 (0)6897 509-01
 Fax +49 (0)6897 509-1726
 E-mail: electronic@hydac.com
 Internet: www.hydac.com