

AirLINE and AirLINE Quick – Electrical/pneumatic Automation System

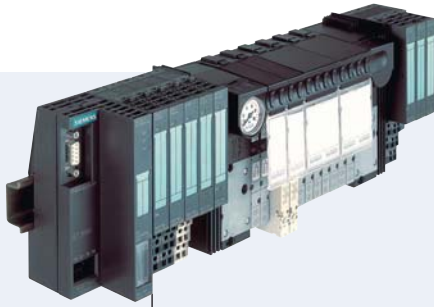

Type 8644 can be combined with...



Type 8032
Switch



Type 6212
Solenoid valve



Type 2012
Process valve



Type 8630
Valve controller



Type 0498
Double pilot controlled check valve

- Fully compatible with Siemens ET 200S
- Combination of Fieldbus, pilot valves and I/O modules
- higher flexibility in the control cabinet with AirLINE Quick
- Optionally integrated PLC functionality
- Compact design
- High flow rate value

The AirLINE System integrates high performance solenoid pilot valves, remote electronic I/O and fieldbus communication into a process actuation and control system that is both compact and extremely flexible. Its modular design allows fully customized, pre-mounted and tested solutions to exactly

meet all application needs including the integration of a local Mini PLC. Due to the full electronic and mechanical integration, the valve block can be added without the need of any tools or wiring.

Technical data	Pilot valve types	
	0460, 6524, 6525	0461, 6526, 6527
width/station	11 mm	16.5 mm
Circuit function	C (3/2-way) D (3/2-way) H (5/2-way) H (5/2-way) impulse L (5/3-way) in middle position all ports locked N (5/3-way) in middle position all ports exhausted	C (3/2-way) D (3/2-way) H (5/2-way) H (5/2-way) impulse L (5/3-way) in middle position all ports locked N (5/3-way) in middle position all ports exhausted
Flow rate	300 l/min (200 l/min for functions H impulse, L and N)	700 l/min (500 l/min for functions H impulse, L and N)
Pressure range	Vac. up to 10 bar	Vac. up to 10 bar
module types	2x and 4x (integrated check valve and P-Shut off valve optional)	2x and 4x (integrated check valve and p-Shut off valve optional) combination of 11mm-modules (3 valves) and 16,5mm- modules is possible.
Max. number of modules	Depending on application	Depending on application
Max. number of valves	64 (by use of Type 0460: 32)	32 (by use of Type 0461: 24)
Fieldbus type	PROFIBUS DP, PROFINET I/O	PROFIBUS DP, PROFINET I/O
Electrical modules	Siemens ET200S	Siemens ET200S
Digital modules	2 or 4 inputs 2 or 4 outputs, others on request	2 or 4 inputs 2 or 4 outputs, others on request
Analogue modules	2 or 4 inputs (0-10 V, 0-20 mA, 4-20 mA, RTD, TC) 2 outputs (0-10 V, 0-20 mA, 4-20 mA) others on request	2 or 4 inputs (0-10 V, 0-20 mA, 4-20 mA, RTD, TC) 2 outputs (0-10 V, 0-20 mA, 4-20 mA) others on request
Operating voltage	24 V/DC	24 V/DC
Voltage tolerance	+20%/−15% (by use of Type 0460: ±10%)	+20%/−15% (by use of Type 0461: ±10%)
Residual ripple	1 Vss	1 Vss

to be continued on page 2

Technical data	Pilot valve types	
	0460, 6524, 6525	0461, 6526, 6527
Nominal power per valve	1 W (0,5 W Nominal power acc. to 120 ms)	2 W (1 W Nominal power acc. to 120 ms)
Rated current per valve	43 mA (28 mA Hold current after 120 ms) 41 mA (by use of Type 0460)	85 mA (52 mA Hold current after 120 ms) 41 mA (by use of Type 0461)
Temperatures		
Ambient	0 to +55°C (by use of Type 0460: 0 to +50°C)	0 to +55°C (by use of Type 0461: 0 to +50°C)
Storage	-20 to +60°C	-20 to +60°C
Protection class	IP20 IP65 in closed field housing	IP20 IP65 in closed field housing
Approvals	Zone 2	on request

Application example

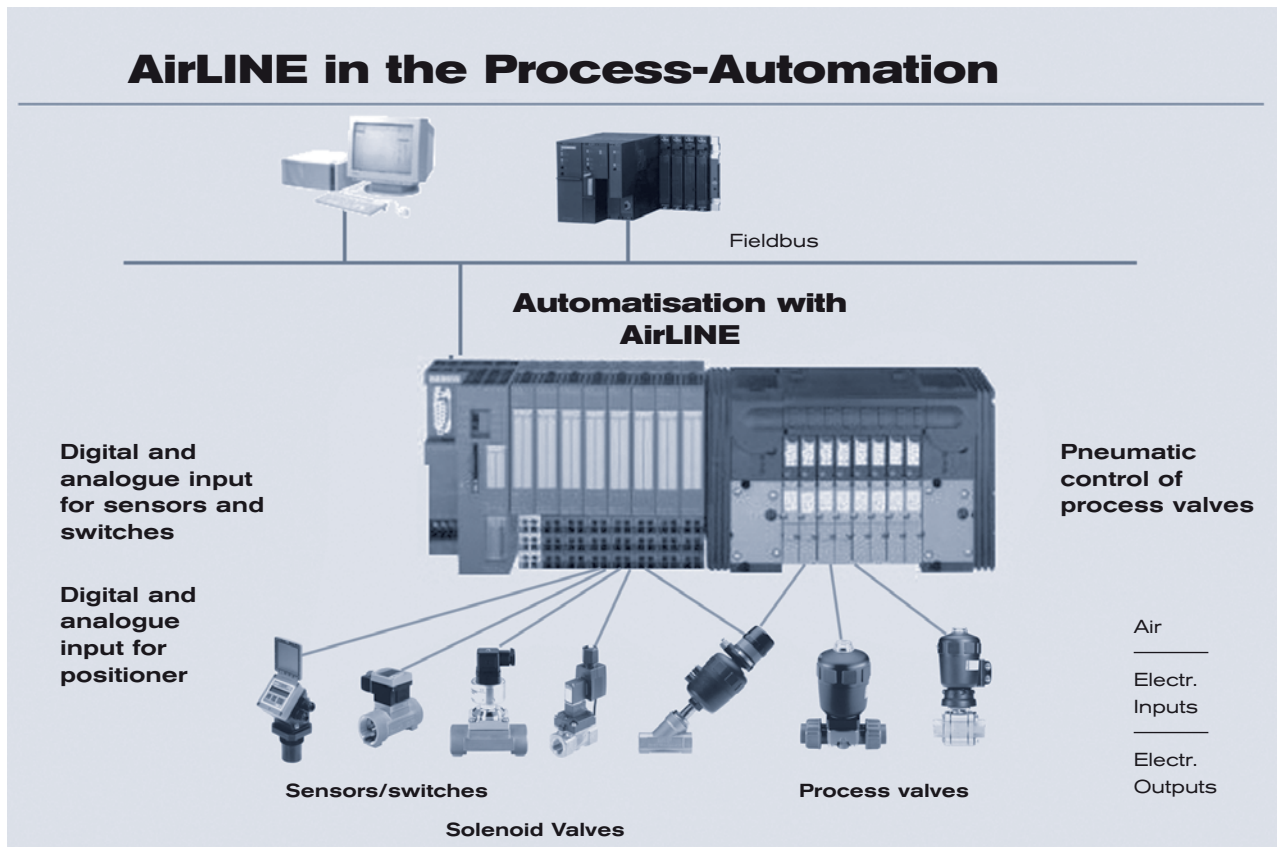

DTS 1000012078 EN Version: K Status: RL (released | freigegeben | valide) printed: 29.08.2013

Configuration software

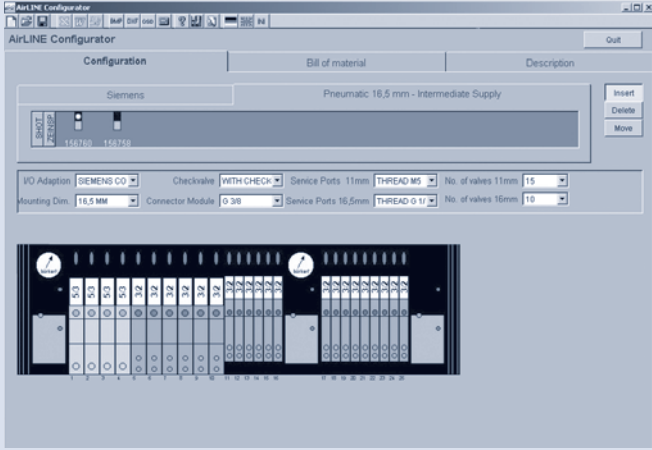

AirLINE is a system of modular design which is precisely adapted to the specific requirements of the customer. Bürkert offers a software programme, the simple, precise generation of the required configuration of each AirLINE system.

The Bürkert Configurator defines:

- Number and types of valves
- Intermediate module

The results supplied by the Configurator:

- the bill of material (including list prices)
- Illustration
- DXF - File
- Documentation
- Dimensions

For more information consult individual datasheets, downloadable at www.burkert.com

11mm width/station Solenoid Valves 6524 and 6525



The solenoid valve Types 6524 and 6525 consist of a 6144 flipper pilot valve and a pneumatic seat valve. The principle allows switching of high pressures together with low power consumption and fast response times. The pilot valves are equipped with manual override as a standard.

Specification	3/2-way valve	2 x 3/2-way valve
Body material	PA (Polyamide)	
seal materials	FPM, NBR and PUR	
Medium	lubricated and non lubricated dry compressed air; neutral gases (5 µm-Filter)	
Port connections	Flange for MP11	
Pneumatic module	Type MP11 with push-in connection Diameter 6 mm, D1/4 Threaded port M7	
Manual override	Standard	
Operating voltage	24 V DC *	
Nominal power	0,8 W	2 x 0,8 W with reduction of power
Duty cycle	Continuous operation (100% ED)	
Electr. connection on valve	Rectangular plug 2-pin grid spacing 5,08 mm	Rectangular plug 3-pin grid spacing 2,54 mm
Mounting	with 2 screws M2 x 20	with 2 screws M2 x 28
Installation	As required, preferably with actuator upright	
Flow rate: QNn value air [l/min]:	Measured at +20°C, 6 bar pressure at valve inlet and 1 bar pressure difference	
Pressure values [bar]:	Overpressure with respect to atmospheric pressure	
Response times [ms]:	Measured according to ISO 12238	

* 10% residual ripple allowed

Ordering chart for valves

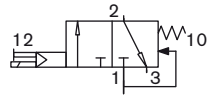
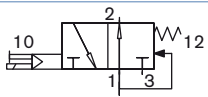
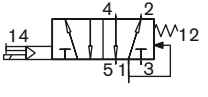
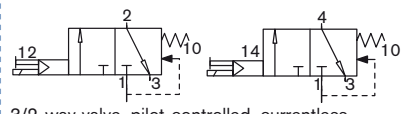
Circuit function	Orifice [mm]	QNn value air [l/min]	Pressure range [bar]	Response times			Item no.
				Opening [ms]	Closing [ms]	Voltage/Frequency [V/Hz]	
 <p>3/2-way valve, pilot-controlled, currentless Port 2 decreased</p>	4	300	Vac.-7	15	20	24 V DC *	186 258
			1-10 ¹⁾	15	20	24 V DC *	186 257
			2,5-10	15	28	24 V DC *	184 043
 <p>3/2-way valve, pilot-controlled, currentless Port 2 pressurised</p>			2,5-10	15	28	24 V DC *	184 400
 <p>5/2-way valve, pilot-controlled, currentless Port 1 connected to port 2, port 4 exhausted</p>	4	300	1,0-10 ¹⁾	15	20	24 V DC *	186 271
			2, 5-10	20	28	24 V DC *	179 938
 <p>3/2-way valve, pilot-controlled, currentless Port 2/4 decreased</p>	4	300	1,0-10 ¹⁾	12	20	24 V DC *	186 259 ²⁾
			2,5-10	12	20	24 V DC *	186 260 ²⁾

¹⁾ Version with auxiliary pilot air

²⁾ Version with integrated reduction of power consumption

* 10% residual ripple allowed

11 mm width/station: pilot valve Type 0460



The solenoid valve Type 0460 consists of a pneumatic valve body fitted with a double coil pilot valve. The principle allows switching of high pressures together with low power consumption and fast response times. All valves are equipped with manual override as a standard.

Technical data	
Body material	Aluminium
Seal material	NBR
Medium	lubricated and non lubricated dry compressed air; Neutral gases (5µm filter recommended)
Port connections	Flange
Pneumatic module	MP11
Supply port connection 1 (P), 3 (R), 5 (S)	G 1/4 NPT 1/4 Push-in connection Ø 10 mm
Service port 2 (A), 4 (B)	Push-in connection Ø 6 mm Push-in connection Ø 1/4" Threaded port M7
Operating voltage	24 V/DC
Electrical connection at the valve	Rectangular plug
Manual override	standard
Flow rate: QNn value air [l/min]	Measured at +20°C, 6 bar pressure at valve inlet and 1 bar pressure difference
Pressure values [bar]	Measured as overpressure to the atmospheric pressure
Response times [ms]	Measured according to ISO 12238

Ordering chart for valves

Circuit function	Orifice [mm]	QNn value air [l/min]:	Pressure range [bar]	Nominal power [W]	Response times		Item no.
					Opening [ms]	Closing [ms]	
<p>5/2-way valve, pilot-controlled, Impulse version</p>	2,5	200	2,0-7,0	1	15	15	154 183
<p>5/3-way-valve, pilot-controlled, in middle position all ports locked</p>	2,5	200	2,0-7,0	1	15	20	154 184
<p>5/3-way-valve, pilot-controlled, in middle position port 2 and 4 exhausted</p>	2,5	200	2,0-7,0	1	15	20	154 185

16,5mm width/station Solenoid Valves 6526 and 6527



The solenoid valve Types 6526 and 6527 consist of a pneumatic valve body fitted with Type 6106 rocker pilot valve. The principle allows switching of high pressures together with low power consumption and fast response times. The pilot valves are equipped with manual override as a standard.

Specification	
Body material	PA (Polyamide)
seal materials	NBR
Medium	lubricated and non lubricated dry compressed air; neutral gases (10 µm filter)
Port connections	Flange for MP12
Pneumatic module	Type MP12 with G 1/8, Push-in connection Ø 8 mm NPT 1/8
Manual override	Standard
Operating voltage	24 V DC
Nominal power	2 W, 1W
Duty cycle	Continuous operation 100%
Electr. connection on valve	Tag connector acc. to DIN EN 175301-803 (previously DIN 43650) Form C
Mounting	with 2 screws M3 x 30
Installation	As required, preferably with actuator upright
Flow rate: QNn value air [l/min]:	Measured as overpressure to the atmospheric pressure 1 bar pressure difference
Pressure values [bar]	Measured as overpressure to the atmospheric pressure
Response times [ms]	Measured according to ISO 12238

Ordering chart for valves

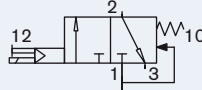
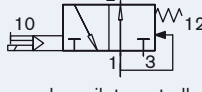
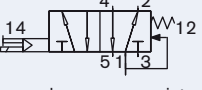
Circuit function	Orifice [mm]	QNn value air [l/min]	Pressure range [bar]	Nominal power [W]	Response times			Item no.
					Opening [ms]	Closing [ms] ³⁾	Voltage/Frequency [V/Hz]	
C  3/2-way valve, pilot-controlled, currentless, Port 2 decreased	6	700	1,0 - 10 ¹⁾	2	20	12	24 V DC	156 842
			1,0 - 10 ¹⁾	2	20	12	24 V DC	163 028 ²⁾
			2,0 - 10	2	20	12	24 V DC	156 318
			2,0 - 10	2	20	12	24 V DC	158 944 ²⁾
			2,0 - 8,0	1	20	17	24 V DC	156 840
D  3/2-way valve, pilot-controlled, currentless, Port 2 pressurized	6	700	1,0 - 10 ¹⁾	2	20	12	24 V DC	163 029 ²⁾
			2,0 - 10	2	12	20	24 V DC	156 320
			2,0 - 10	2	20	12	24 V DC	158 946 ²⁾
			2,0 - 8,0	1	17	20	24 V DC	156 841
H  5/2-way valve, servo-assisted in de-energised position port 1 connected to port 2, port 4 exhausted	6	700	1,0 - 10 ¹⁾	2	20	12	24 V DC	156 828
			1,0 - 10 ¹⁾	2	20	12	24 V DC	163 030 ²⁾
			2,0 - 10	2	20	12	24 V DC	156 337
			2,0 - 10	2	20	12	24 V DC	158 942 ²⁾
			2,0 - 8,0	1	20	17	24 V DC	156 827
			2,0 - 8,0	1	20	12	24 V DC	158 943 ²⁾

¹⁾ Version with auxiliary pilot air

²⁾ Electric connection with manual override.

³⁾ Closing time approx. 5 ms higher when used together with valve unit

More valve options

Covering plates

When all the valve connections in a basic valve unit module are not used, then these connections should be covered by the appropriate covering plate for full efficiency.

Covering plates	Item no.
Covering plate for solenoid valve Type 6524/6525	650 373
Covering plate for solenoid valve Type 6524 2 x 3/2-way valve	661 092
Covering plate for solenoid valve Type 6526/6527	653 765

Exhaust plates

An exhaust plate is mounted on the pneumatic module of the valve unit and offers an additional possibility to remove compressed air from the system.

Exhaust plates	Item no.
Exhaust air plate complete Type 6524/6525	655 166
Exhaust air plate complete Type 6526/6527	653 697

16,5 mm width/station: pilot valve Type 0461



The solenoid valve Type 0461 consists of a pneumatic valve body fitted with a double coil pilot valve. The principle allows switching of high pressures together with low power consumption and fast response times. All valves are equipped with manual override as a standard.

Technical data	
Body material	Aluminium
Seal material	NBR
Medium	lubricated and non lubricated dry compressed air; Neutral gases (10µm filter recommended)
Port connections	Flange
Pneumatic module	MP12
Supply port connection 1 (P), 3 (R), 5 (S)	G 3/8 NPT 3/8
Service port 2 (A), 4 (B)	G 1/8 NPT 1/8 Push-in connection Ø 8 mm
Operating voltage	24 V/DC
Electrical connection at the valve	Rectangular plug
Manual override	standard
Flow rate: QNn value air [l/min]	Measured at +20°C, 6 bar pressure at valve inlet and 1 bar pressure difference
Pressure values [bar]	Measured as overpressure to the atmospheric pressure
Response times [ms]	Measured according to ISO 12238

Ordering chart for valves

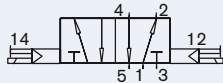
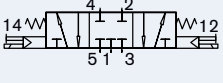
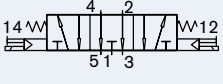
Circuit function	Orifice [mm]	QNn value air [l/min]	Pressure range ²⁾ [bar]	Nominal power [W]	Response times		Item no.
					Opening [ms]	Closing [ms]	
H  5/2-way valve, pilot-controlled, Impulse version	6	500	2,5-7,0	1	20	30	156 766
L  5/3-way-valve, pilot-controlled, in middle position all ports locked	6	500	2,5-7,0	1	15	50	156 767
N  5/3-way-valve, pilot-controlled, in middle position port 2 and 4 exhausted	6	500	2,5-7,0	1	15	50	156 768

AirLINE Quick

With AirLINE Quick you can reduce the amount of the components in the control cabinet considerably. With the AirLINE Quick Adapter the valve island is directly adapted on the control cabinet floor or wall.

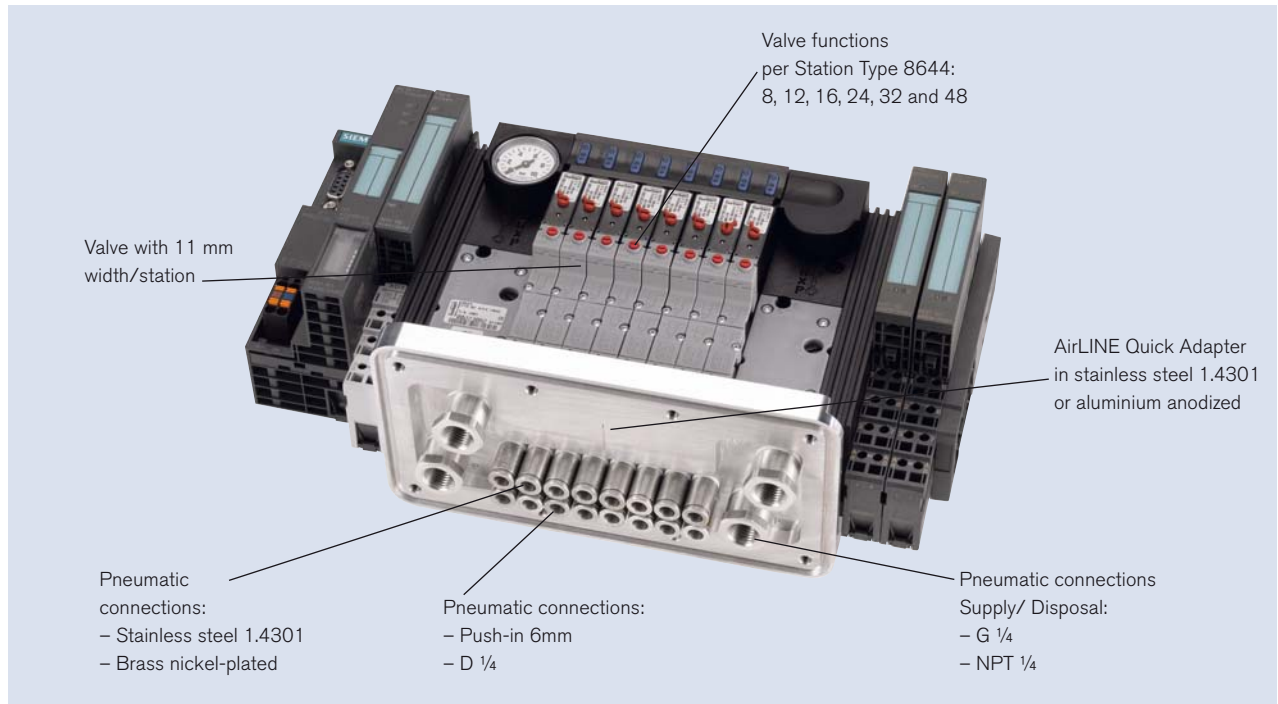

* The valves of Type 0460 can not be installed with AirLINE Quick because of their size.

Technical data

Technical data	
Material AirLINE Quick Adapter	stainless steel 1.4301 aluminium anodized
Material pneumatic connection	stainless steel 1.4301 Brass nickel-plated
Connection pneumatic feeding	G 1/4, NPT 1/4
Connection pneumatic service ports	Push-in D6 mm, D1/4"
Installation	Control cabinet wall Control cabinet floor
Valve functions per station	8, 12, 16, 24, 32 and 48

Additional accessories for AirLINE Quick

Blanking plates

A blanking plate is used to cover an existing flange for AirLINE Quick on the cabinet wall or on the cabinet floor.

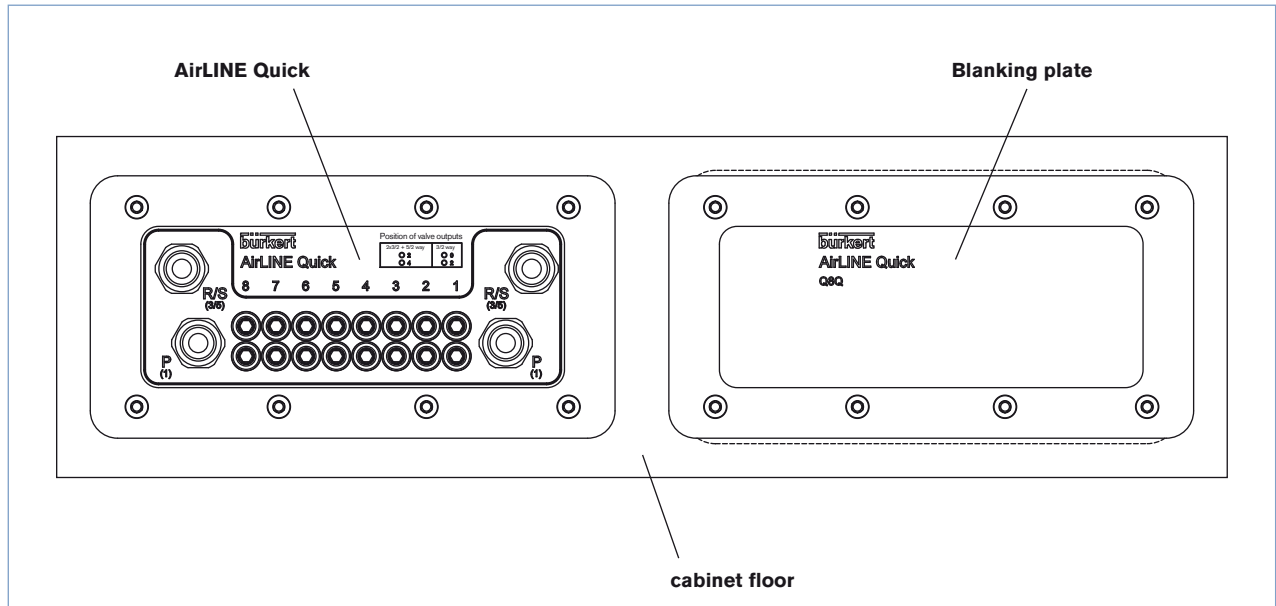

Ordering chart blanking plates

Material	Amount of valve slots	Item no.
Aluminium anodized	8	246 933
	12	246 929
	16	246 925
	16*	246 935
	24	246 927
Stainless steel 1.4301	24*	246 931
	8	246 934
	12	246 930
	16	246 926
	16*	246 936
	24	246 928
	24*	246 932

* with intermediate pneumatic supply module

Pneumatic module and electrical interfaces for modules series Siemens

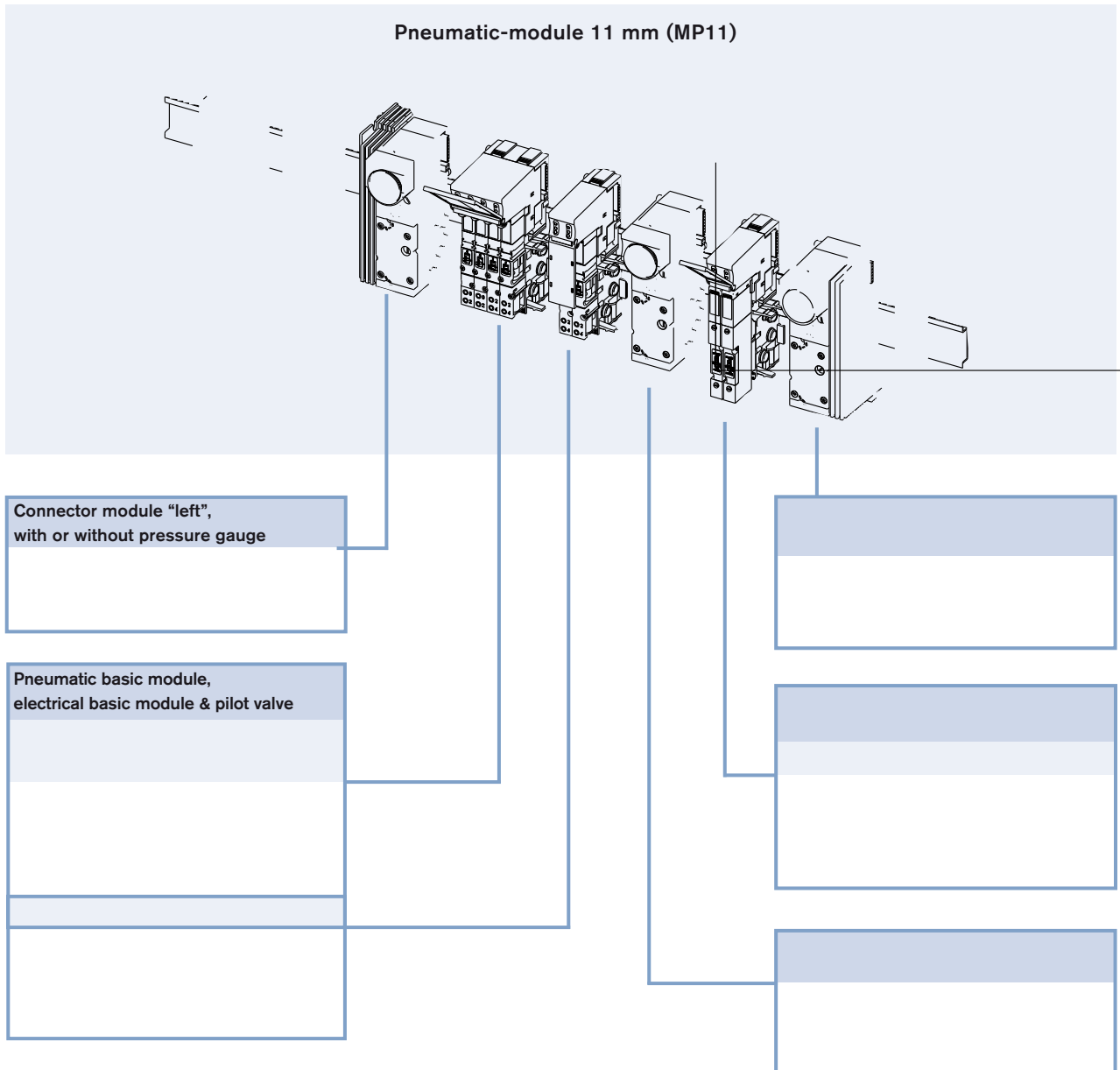

Pneumatic module and electrical interfaces for modules series Siemens

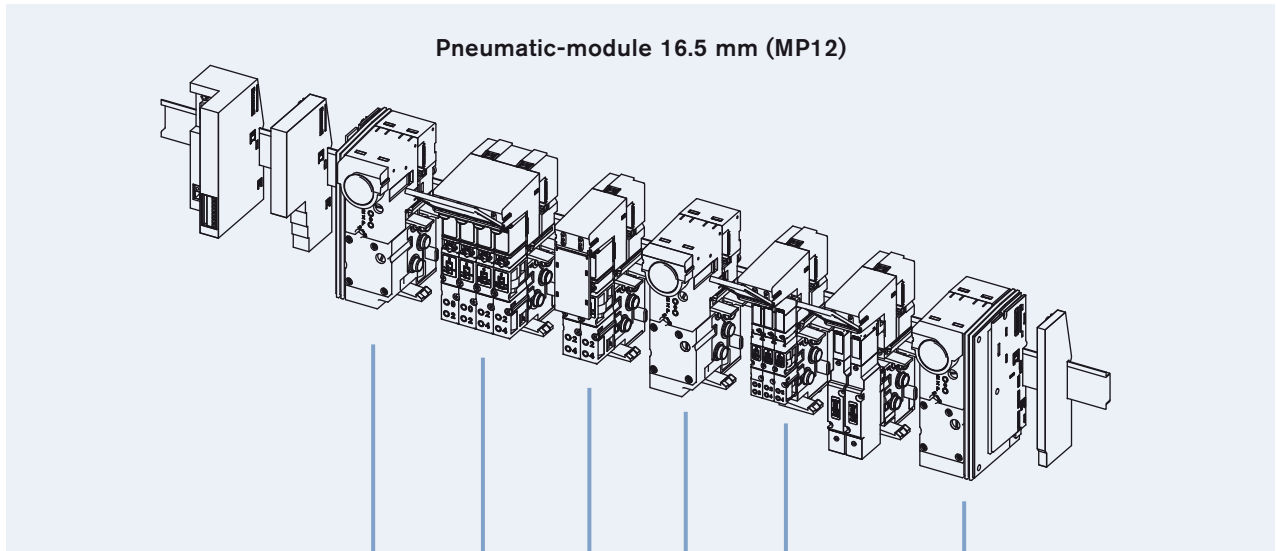

Pneumatic-module 16.5 mm (MP12)

**Connector module "left",
with or without pressure gauge**

Threaded port G 3/8
Threaded port NPT 3/8

**Pneumatic basic module,
electrical basic module & pilot valve**

4-fold (4 x 16,5 mm)

Service port 2 (A), 4 (B)
Threaded port G1/8
Threaded port NPT1/8
Push-in connection Ø 8 mm

2-fold (2 x 16,5 mm)

Service port 2 (A), 4 (B)
Threaded port G1/8
Threaded port NPT1/8
Push-in connection Ø 8 mm

**Connector module "right",
with or without pressure gauge**

Threaded port G 3/8
Threaded port NPT 3/8

**Pneumatic basic module,
electrical basic module & pilot valve**

3-fold (3 x 11 mm)

Service port 2 (A), 4 (B)
Threaded port M7
Push-in connection Ø 6 mm

**Intermediate module,
with or without pressure gauge**

Threaded port G 3/8
Threaded port NPT 3/8

Dimensions [mm]

width/station 11 mm, with Type 6524 / 6525

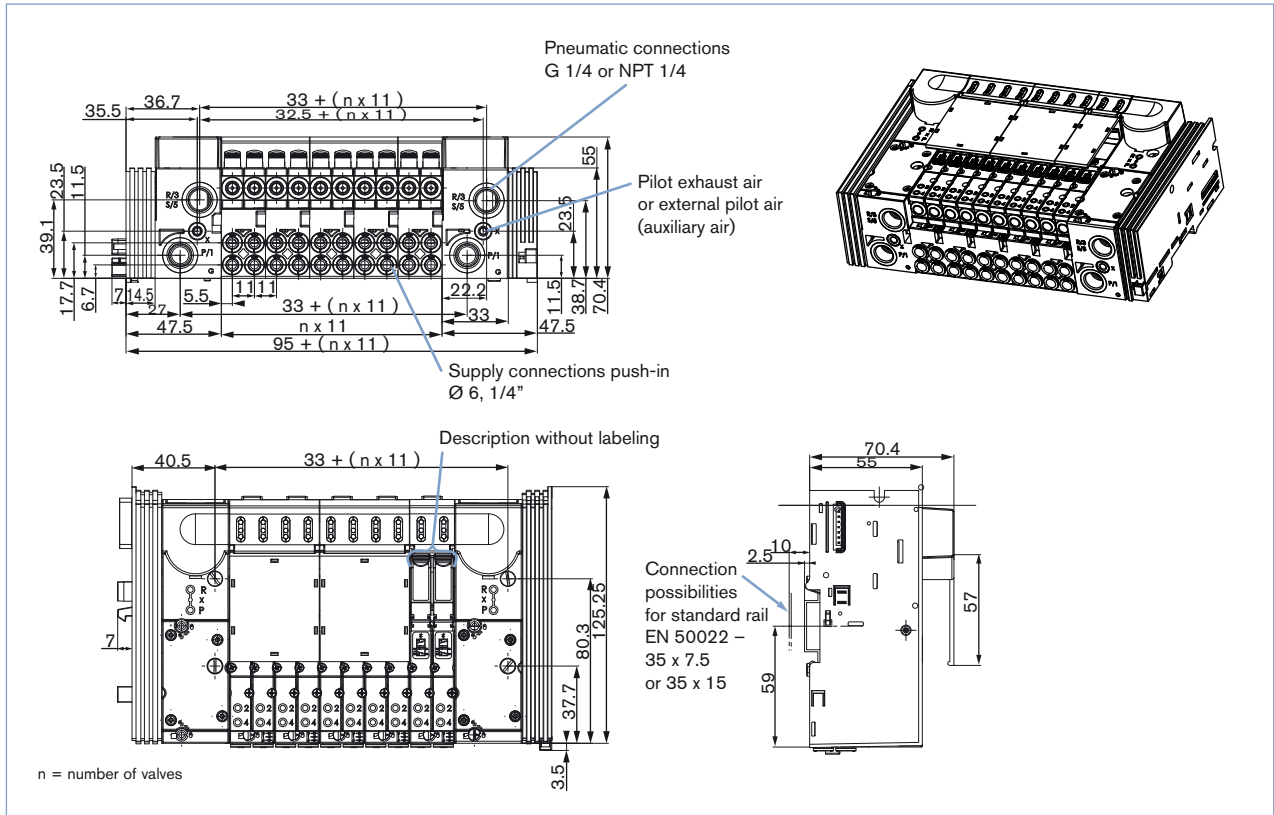

width/station 11 mm, with Type 6524 2 x 3/2-way valve

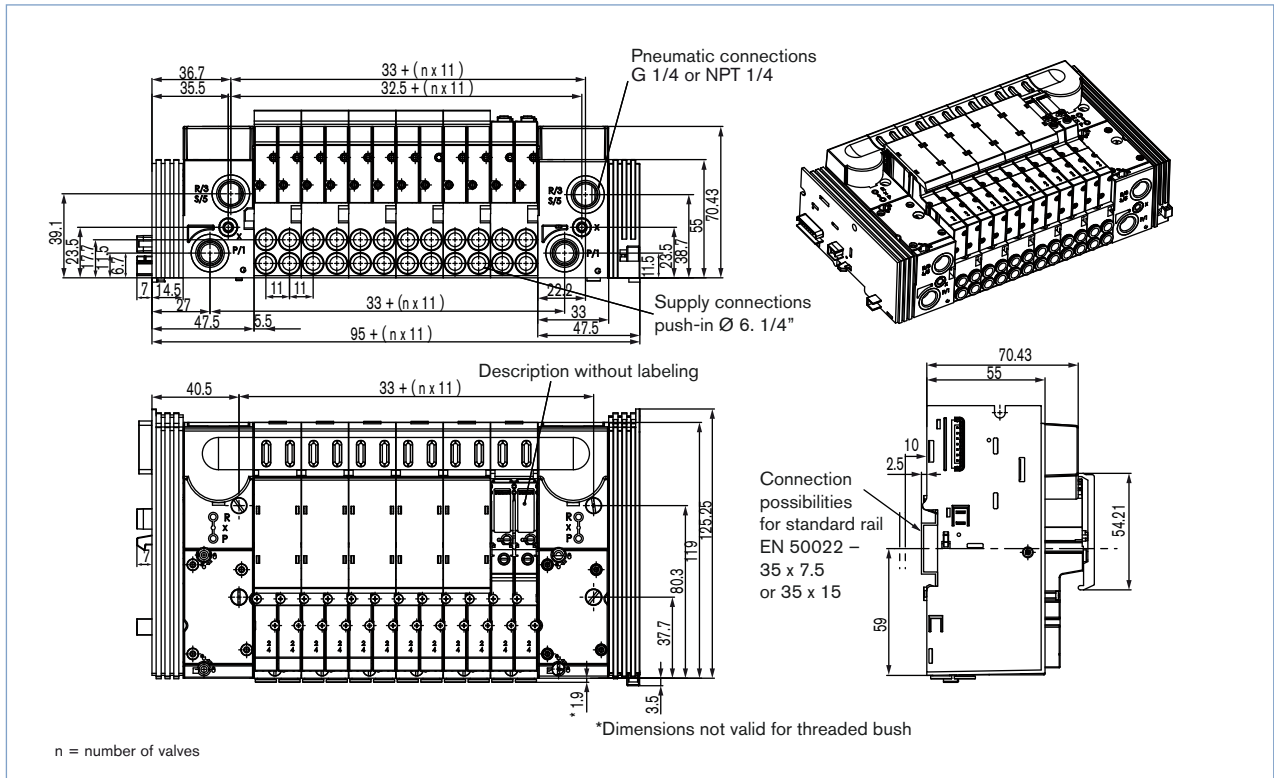

DTS 1000012078 EN Version: K Status: RL (released | freigegeben | valide) printed: 29.08.2013

Dimensions [mm]

width/station 16,5 mm, for Type 6526 / 6527

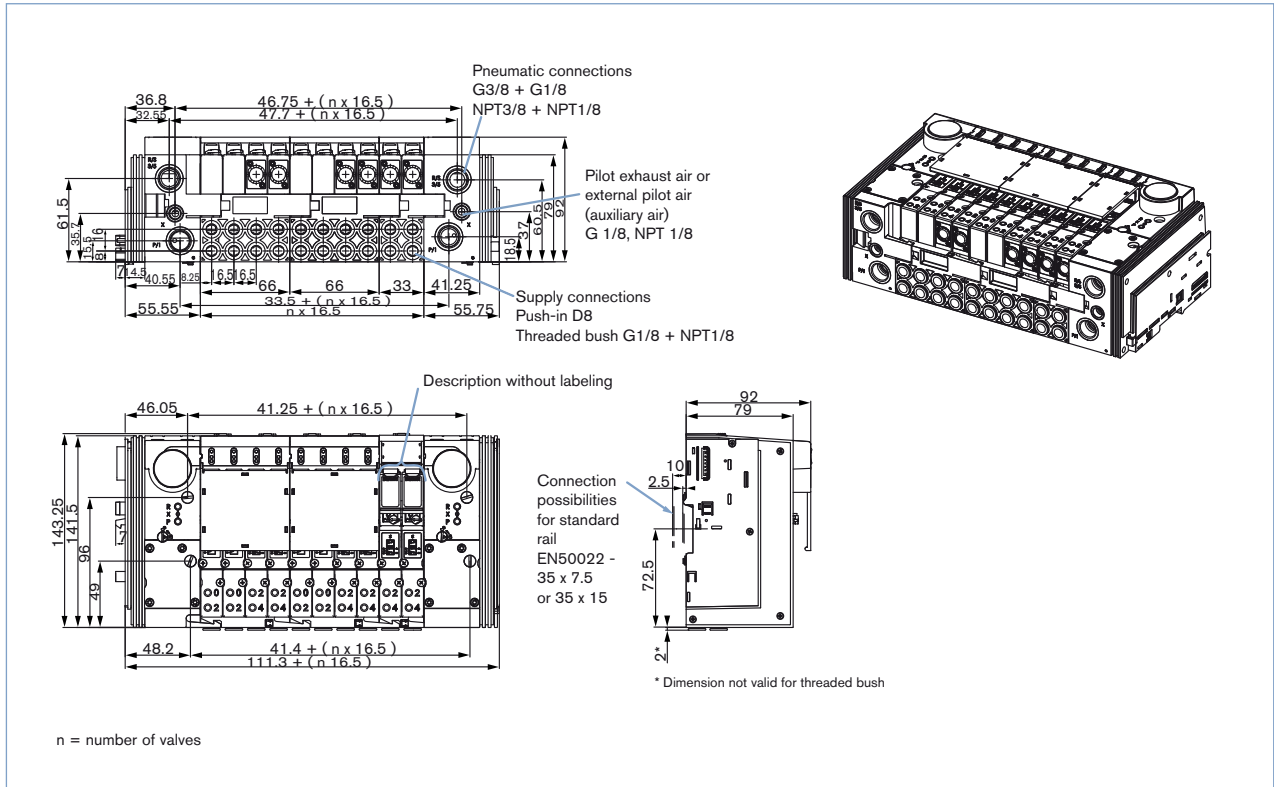

DTS 1000012078 EN Version: K Status: RL (released | freigegeben | valide) printed: 29.08.2013

To find your nearest Bürkert facility, click on the orange box



www.burkert.com

In case of special application conditions, please consult for advice.

We reserve the right to make technical changes without notice.

1211/7_EU_en_00891880